

BeCALM: Multiplication Concepts

Beginning Curriculum for Adults Learning Math
Remote-Ready Curriculum

STUDENT PACKET



Created with funding from the Adult and Community Learning Services division of the Massachusetts Department of Elementary and Secondary Education by the SABES Mathematics and Adult Numeracy Curriculum & Instruction PD Center, which is managed by TERC, Inc.

Acknowledgements

The titles in the BeCALM series were developed by Melissa Braaten for the SABES Mathematics and Adult Numeracy Curriculum & Instruction PD Center, with contributions from Yvonne Readdy and Sherry Soares.

The activities on pages 4 and 8:

Investigations Grade 3, Curriculum Unit: “THINGS THAT COME IN GROUPS” © 1998 by Savvas Learning Company LLC, or its affiliates. Used by permission. All rights reserved. [NOTE: The presented content is for example only, and may not appear in the same format (or order) as the original publication.]

The activity on page 7:

by Jo Boaler/YouCubed. Licensed under CC BY 4.0.

The activities on pages 31–39, 41–43, 48–50, and 80–82:

EMPower Plus book *Everyday Number Sense: Mental Math and Visual Models*

UNIT 1: Visual Patterns in Multiplication

Financial Literacy: Beliefs and Attitudes about Money

From my culture

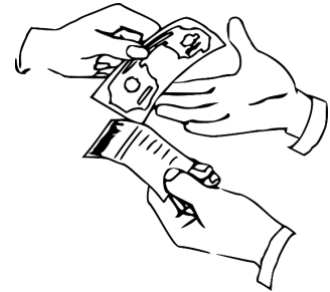

From my family

My personal beliefs and attitudes about money

Things That Come in Groups

We often want to count items in groups, rather than one by one. Multiplication is a way to count things in equal sized groups.

Shoes and socks are sold in pairs (groups of 2), tires may be sold in groups of 4, and eggs are often sold in groups of 12 (a dozen). Do you buy drinks that come in six-packs? What can you think of that is usually sold in groups of a certain size?

There are also “groups” that are not physical objects. We create ten- and twenty-dollar bills so we can count money more easily. We make groups out of measurements, such as grouping 7 days into a week, 60 seconds into a minute, or 12 inches into a foot.

Brainstorm below some other groups you encounter in your daily life.

| Groups of 5 | Groups of 10 | Groups of 100 |
|----------------------------|----------------------------|----------------|
| Example: fingers on a hand | Example: years in a decade | |
| Groups of ____ | Groups of ____ | Groups of ____ |
| | | |

Adapted from Investigations Grade 3, Curriculum Unit: “THINGS THAT COME IN GROUPS” © 1998 by Savvas Learning Company LLC, or its affiliates. Used by permission. All rights reserved. [NOTE: The presented content is for example only, and may not appear in the same format (or order) as the original publication.]

Vocabulary List for This Unit

| Word | Definition | Example |
|------|------------|---------|
| | | |
| | | |
| | | |
| | | |

| Word | Definition | Example |
|------|------------|---------|
| | | |
| | | |
| | | |
| | | |

Visual Numbers

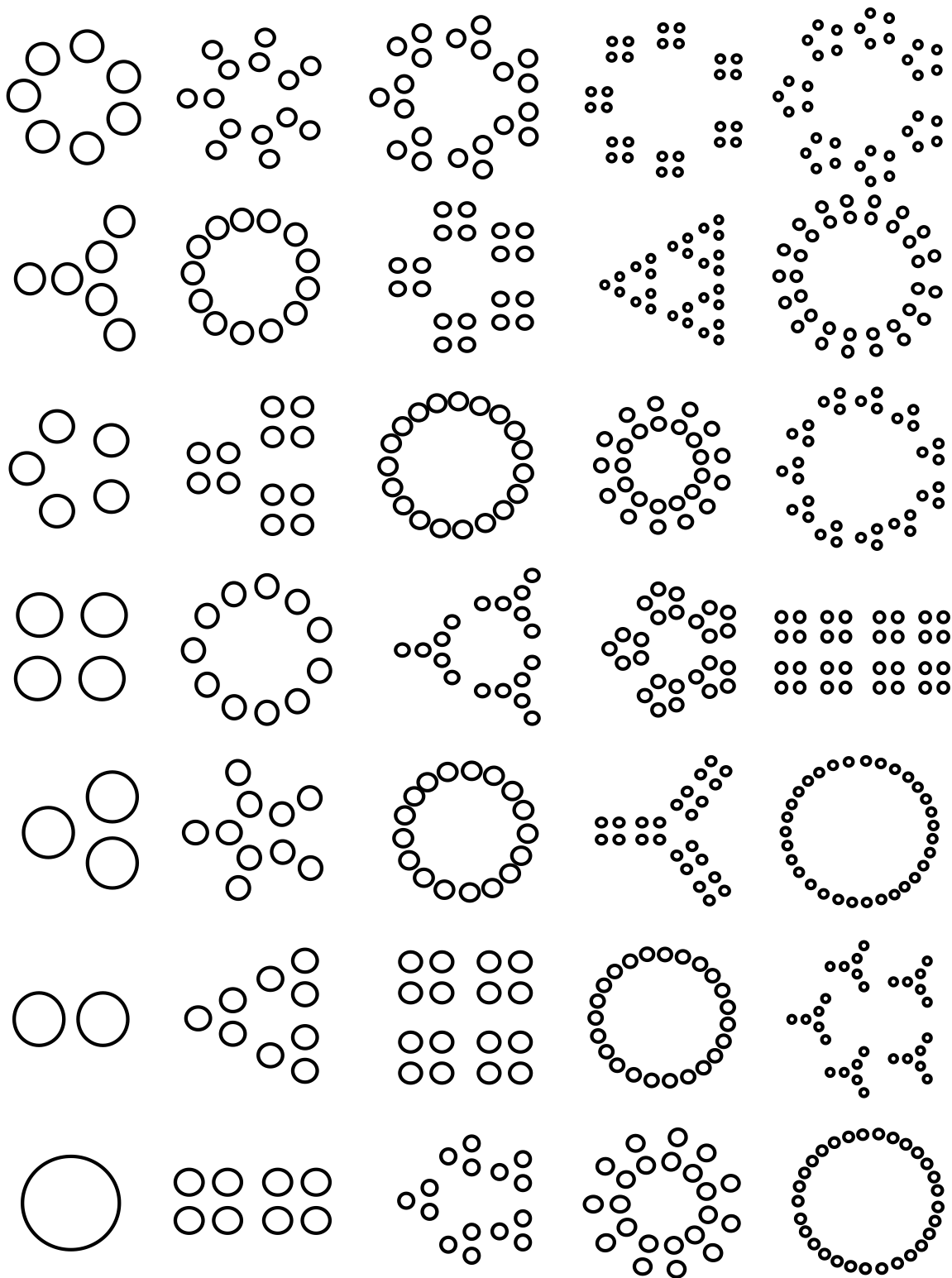

Activity images by Jo Boaler/YouCubed. Licensed under CC BY 4.0.
<https://www.youcubed.org/wp-content/uploads/2019/08/WIM-Number-Visuals-Grades-3-5.pdf>

Arrays That Total 36

Here are five arrays for 36.

1. Label the dimensions of each array.
2. Write a multiplication sentence for each array.

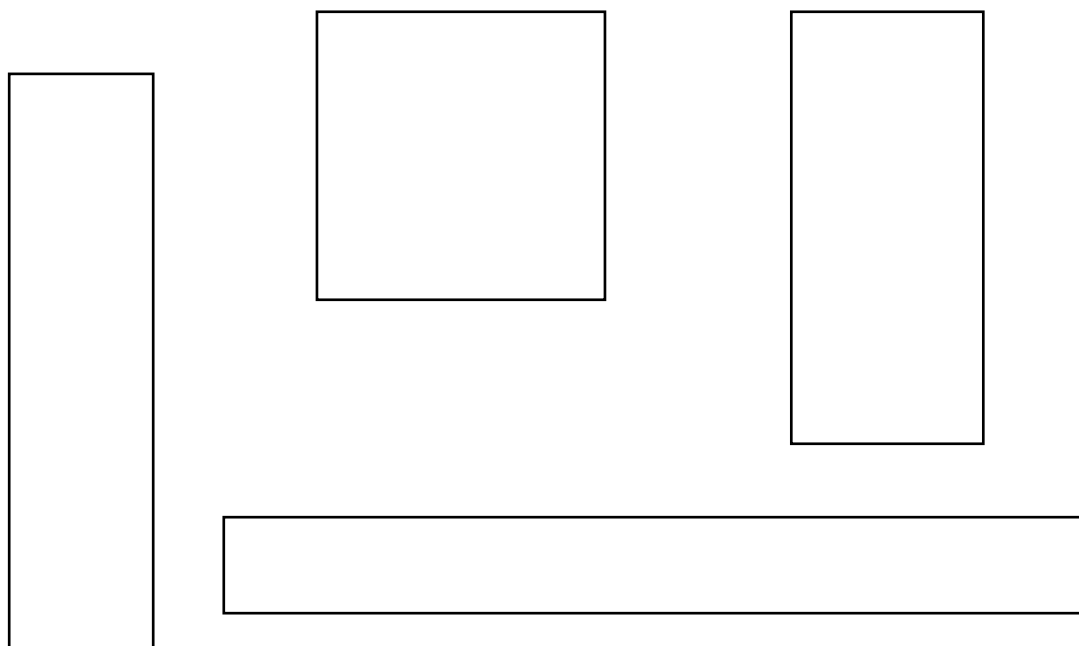

3. List all the factors of 36 here:
4. Explain how you did one of these problems.

From Investigations Grade 3, Curriculum Unit: "THINGS THAT COME IN GROUPS" © 1998 by Savvas Learning Company LLC, or its affiliates. Used by permission. All rights reserved. [NOTE: The presented content is for example only, and may not appear in the same format (or order) as the original publication.]

Talking About Groups

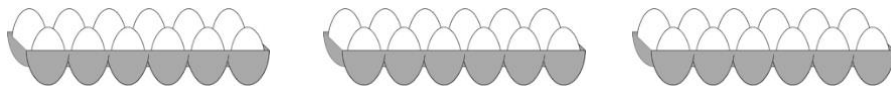
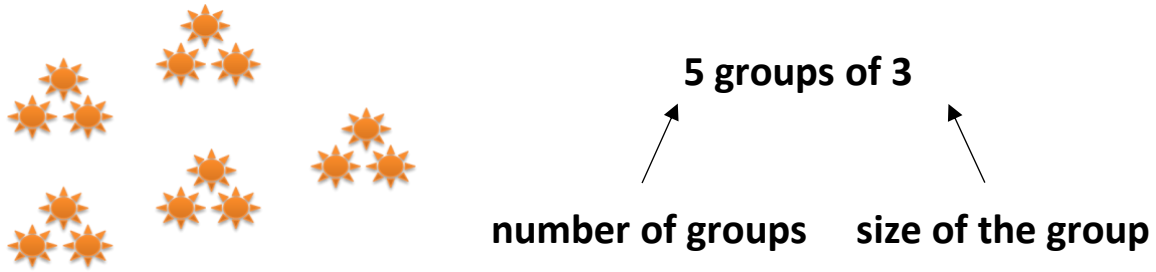

_____ groups of _____

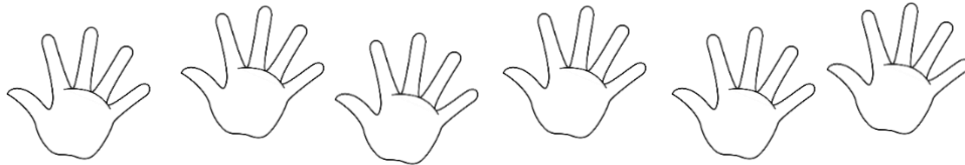

_____ groups of _____

| Draw "3 groups of 2" | Draw "2 groups of 4" |
|----------------------|----------------------|
| | |

Talking About Multiplication

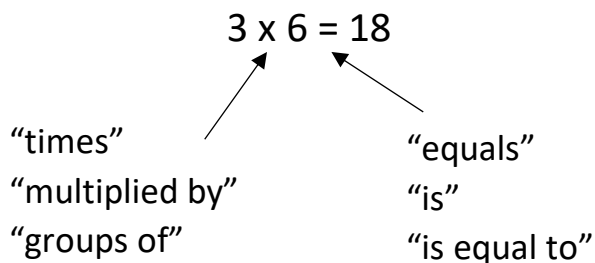

Examples:

3 times 6 equals 18.

3 multiplied by 6 is 18.

3 groups of 6 is equal to 18.

| | | | | | |
|--|--|--|--|--|--|
| | | | | | |
| | | | | | |
| | | | | | |

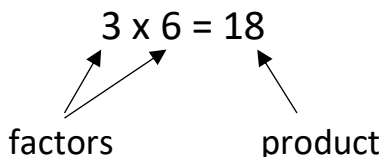

Examples:

18 is the product of 3 and 6.

3 and 6 are factors of 18.

Other factors of 18 are 1, 2, 9, and 18.

Exit Ticket/Homework

Choose one of the options below.

Choice 1: Find a number for which you can draw at least three different arrays. Sketch them below.

Choice 2: Find the number under 50 that has the most arrays. Explain how you know with words, pictures, or equations.

Name _____ Date _____

Multiplication Concepts: Unit 1, Visual Patterns in Multiplication

| Objective | My Progress (Struggling, Learning, Mastery) |
|--|--|
| I can identify factors and products. | |
| I can see and describe visual patterns in factors and products. | |
| I can break up a pattern into smaller parts. (Quick Images) | |
| I can write expressions equal to a target number. (Number of the Day) | |

UNIT 2: Number Patterns in Multiplication

Financial Literacy: Costs That Repeat

Subscription and membership fees:

Examples:

Payment plans:

Examples:

Products that are consumed:

Examples:

Other costs that repeat:

Fatima pays \$12 per month for internet in her home.



How much does she pay for 6 months of internet?
Show your thinking below.

For the examples below, write an addition expression and a multiplication expression that could be used to find the total cost.

Example: Gym Membership

\$30 per month for 6 months

| | |
|-------------------------------|----------------------|
| Using repeated addition | Using multiplication |
| $30 + 30 + 30 + 30 + 30 + 30$ | 30×6 |

1) Video Streaming Service: \$8 per month for 12 months (1 year)



| | |
|-------------------------|----------------------|
| Using repeated addition | Using multiplication |
| | |

2) Car Payments: \$120 per month for 3 months



| | |
|-------------------------|----------------------|
| Using repeated addition | Using multiplication |
| | |

3) Prescription Medications: \$15 per month for 4 months



| | |
|-------------------------|----------------------|
| Using repeated addition | Using multiplication |
| | |

Vocabulary List for This Unit

| Word | Definition | Example |
|-------------|-------------------|----------------|
| | | |
| | | |
| | | |
| | | |

| Word | Definition | Example |
|-------------|-------------------|----------------|
| | | |
| | | |
| | | |
| | | |

Multiplication Table (grid)

| x | 1 | 2 | 3 | 4 | 5 | 6 | 7 | 8 | 9 | 10 |
|----|----|----|----|----|----|----|----|----|----|-----|
| 1 | 1 | 2 | 3 | 4 | 5 | 6 | 7 | 8 | 9 | 10 |
| 2 | 2 | 4 | 6 | 8 | 10 | 12 | 14 | 16 | 18 | 20 |
| 3 | 3 | 6 | 9 | 12 | 15 | 18 | 21 | 24 | 27 | 30 |
| 4 | 4 | 8 | 12 | 16 | 20 | 24 | 28 | 32 | 36 | 40 |
| 5 | 5 | 10 | 15 | 20 | 25 | 30 | 35 | 40 | 45 | 50 |
| 6 | 6 | 12 | 18 | 24 | 30 | 36 | 42 | 48 | 54 | 60 |
| 7 | 7 | 14 | 21 | 28 | 35 | 42 | 49 | 56 | 63 | 70 |
| 8 | 8 | 16 | 24 | 32 | 40 | 48 | 56 | 64 | 72 | 80 |
| 9 | 9 | 18 | 27 | 36 | 45 | 54 | 63 | 72 | 81 | 90 |
| 10 | 10 | 20 | 30 | 40 | 50 | 60 | 70 | 80 | 90 | 100 |

Multiplication Table (lists)

| | | | | | |
|--------------------|--------------------|---------------------|----------------------|----------------------|----------------------|
| $1 \times 0 = 0$ | $2 \times 0 = 0$ | $3 \times 0 = 0$ | $4 \times 0 = 0$ | $5 \times 0 = 0$ | $6 \times 0 = 0$ |
| $1 \times 1 = 1$ | $2 \times 1 = 2$ | $3 \times 1 = 3$ | $4 \times 1 = 4$ | $5 \times 1 = 5$ | $6 \times 1 = 6$ |
| $1 \times 2 = 2$ | $2 \times 2 = 4$ | $3 \times 2 = 6$ | $4 \times 2 = 8$ | $5 \times 2 = 10$ | $6 \times 2 = 12$ |
| $1 \times 3 = 3$ | $2 \times 3 = 6$ | $3 \times 3 = 9$ | $4 \times 3 = 12$ | $5 \times 3 = 15$ | $6 \times 3 = 18$ |
| $1 \times 4 = 4$ | $2 \times 4 = 8$ | $3 \times 4 = 12$ | $4 \times 4 = 16$ | $5 \times 4 = 20$ | $6 \times 4 = 24$ |
| $1 \times 5 = 5$ | $2 \times 5 = 10$ | $3 \times 5 = 15$ | $4 \times 5 = 20$ | $5 \times 5 = 25$ | $6 \times 5 = 30$ |
| $1 \times 6 = 6$ | $2 \times 6 = 12$ | $3 \times 6 = 18$ | $4 \times 6 = 24$ | $5 \times 6 = 30$ | $6 \times 6 = 36$ |
| $1 \times 7 = 7$ | $2 \times 7 = 14$ | $3 \times 7 = 21$ | $4 \times 7 = 28$ | $5 \times 7 = 35$ | $6 \times 7 = 42$ |
| $1 \times 8 = 8$ | $2 \times 8 = 16$ | $3 \times 8 = 24$ | $4 \times 8 = 32$ | $5 \times 8 = 40$ | $6 \times 8 = 48$ |
| $1 \times 9 = 9$ | $2 \times 9 = 18$ | $3 \times 9 = 27$ | $4 \times 9 = 36$ | $5 \times 9 = 45$ | $6 \times 9 = 54$ |
| $1 \times 10 = 10$ | $2 \times 10 = 20$ | $3 \times 10 = 30$ | $4 \times 10 = 40$ | $5 \times 10 = 50$ | $6 \times 10 = 60$ |
| $1 \times 11 = 11$ | $2 \times 11 = 22$ | $3 \times 11 = 33$ | $4 \times 11 = 44$ | $5 \times 11 = 55$ | $6 \times 11 = 66$ |
| $1 \times 12 = 12$ | $2 \times 12 = 24$ | $3 \times 12 = 36$ | $4 \times 12 = 48$ | $5 \times 12 = 60$ | $6 \times 12 = 72$ |
| | | | | | |
| $7 \times 0 = 0$ | $8 \times 0 = 0$ | $9 \times 0 = 0$ | $10 \times 0 = 0$ | $11 \times 0 = 0$ | $12 \times 0 = 0$ |
| $7 \times 1 = 7$ | $8 \times 1 = 8$ | $9 \times 1 = 9$ | $10 \times 1 = 10$ | $11 \times 1 = 11$ | $12 \times 1 = 12$ |
| $7 \times 2 = 14$ | $8 \times 2 = 16$ | $9 \times 2 = 18$ | $10 \times 2 = 20$ | $11 \times 2 = 22$ | $12 \times 2 = 24$ |
| $7 \times 3 = 21$ | $8 \times 3 = 24$ | $9 \times 3 = 27$ | $10 \times 3 = 30$ | $11 \times 3 = 33$ | $12 \times 3 = 36$ |
| $7 \times 4 = 28$ | $8 \times 4 = 32$ | $9 \times 4 = 36$ | $10 \times 4 = 40$ | $11 \times 4 = 44$ | $12 \times 4 = 48$ |
| $7 \times 5 = 35$ | $8 \times 5 = 40$ | $9 \times 5 = 45$ | $10 \times 5 = 50$ | $11 \times 5 = 55$ | $12 \times 5 = 60$ |
| $7 \times 6 = 42$ | $8 \times 6 = 48$ | $9 \times 6 = 54$ | $10 \times 6 = 60$ | $11 \times 6 = 66$ | $12 \times 6 = 72$ |
| $7 \times 7 = 49$ | $8 \times 7 = 56$ | $9 \times 7 = 63$ | $10 \times 7 = 70$ | $11 \times 7 = 77$ | $12 \times 7 = 84$ |
| $7 \times 8 = 56$ | $8 \times 8 = 64$ | $9 \times 8 = 72$ | $10 \times 8 = 80$ | $11 \times 8 = 88$ | $12 \times 8 = 96$ |
| $7 \times 9 = 63$ | $8 \times 9 = 72$ | $9 \times 9 = 81$ | $10 \times 9 = 90$ | $11 \times 9 = 99$ | $12 \times 9 = 108$ |
| $7 \times 10 = 70$ | $8 \times 10 = 80$ | $9 \times 10 = 90$ | $10 \times 10 = 100$ | $11 \times 10 = 110$ | $12 \times 10 = 120$ |
| $7 \times 11 = 77$ | $8 \times 11 = 88$ | $9 \times 11 = 99$ | $10 \times 11 = 110$ | $11 \times 11 = 121$ | $12 \times 11 = 132$ |
| $7 \times 12 = 84$ | $8 \times 12 = 96$ | $9 \times 12 = 108$ | $10 \times 12 = 120$ | $11 \times 12 = 132$ | $12 \times 12 = 144$ |

Patterns I See in the Multiplication Table

Describe a pattern that you see.

Useful words:

odd/evenones place tens place multiples of

Describe another pattern that you see.

Useful words:

odd/evenones place tens place multiples of

Equations

These are **equations**.

$$2 \times 3 = 6$$

$$6 = 2 + 2 + 2$$

$$6 \times 1 = 3 \times 2$$

$$2 \times 3 = 3 + 3$$

What do they have in common?

What is different? Do any of them surprise you?

Two Truths and a Lie

Two of these statements are true, and one is false.

Can you find the lie?

A) $4 + 4 + 4 = 3 + 3 + 3 + 3$

B) $5 \times 3 = 15 - 5$

C) $2 \times 3 = 2 + 2 + 2$

Two of these statements are true, and one is false.

Can you find the lie?

A) $10 + 0 = 5 \times 2$

B) $6 + 6 + 6 = 6 \times 3$

C) $4 \times 6 = 24 + 2$

Talking About Multiplication

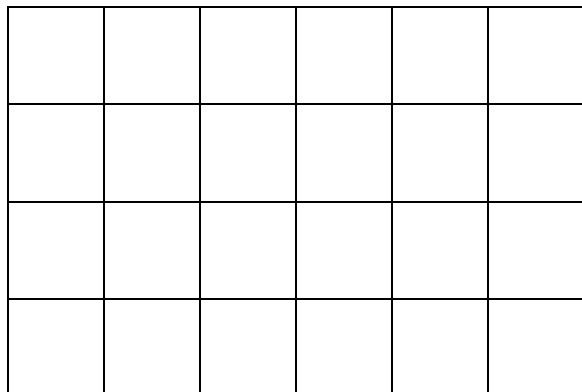

There are 4 groups of 6.

4 and 6 are **factors**.

24 is the **product**.

Length: 6

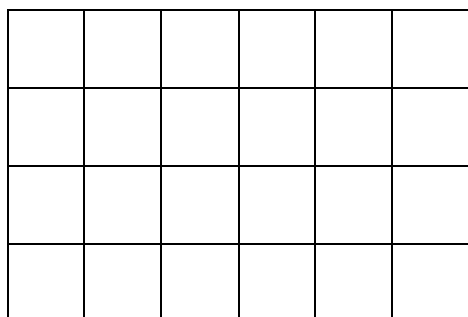

Width: 4

The **length** is 6. The **width** is 4.

This rectangle is 6 **by** 4.

The **area** of the rectangle is 24.

Practice describing each array using the language of rectangles.

A)

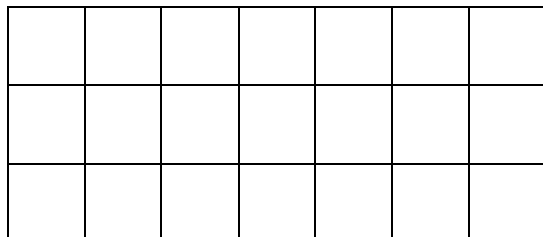

The length is _____. The width is _____.

This rectangle is _____ by _____.

The area of this rectangle is _____.

B)

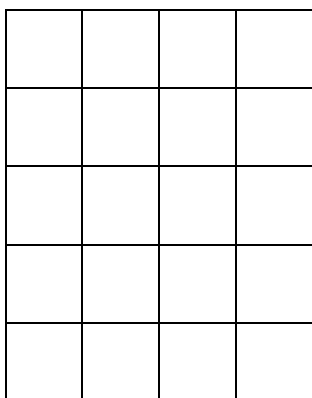

The length is _____. The width is _____.

This rectangle is _____ by _____.

The area of this rectangle is _____.

Exit Ticket/Homework

Create your own two truths and a lie below.

Two of the equations must be true, one must be false.

Name _____ Date _____

Multiplication Concepts: Unit 2, Number Patterns in Multiplication

| Objective | My Progress (Struggling, Learning, Mastery) |
|--|--|
| I can find number patterns in factors and products. | |
| I understand that the equal sign means that the right and left side have the same value. | |
| I can break up a pattern into smaller parts. (Quick Images) | |
| I can write expressions equal to a target number. (Number of the Day) | |
| I can decide if a math sentence is true or false. (Two Truths and a Lie) | |

UNIT 3: Equivalent Expressions

Financial Literacy: One-Time Purchase or Subscription?



Jean-Pierre just bought a new computer. He wants to be able to create documents on it using a word processing program.

He has two choices:

- He can buy the program and download it on his computer for \$160. (One time purchase)
- He can pay for a subscription that allows him to use the program. This costs \$50 per year. (Subscription)

One time Purchase (\$160)

| Pros | Cons |
|------|------|
| | |

Subscription (\$50 per year)

| Pros | Cons |
|------|------|
| | |

Vocabulary List for This Unit

| Word | Definition | Example |
|------|------------|---------|
| | | |
| | | |
| | | |
| | | |

| Word | Definition | Example |
|------|------------|---------|
| | | |
| | | |
| | | |
| | | |

Windows

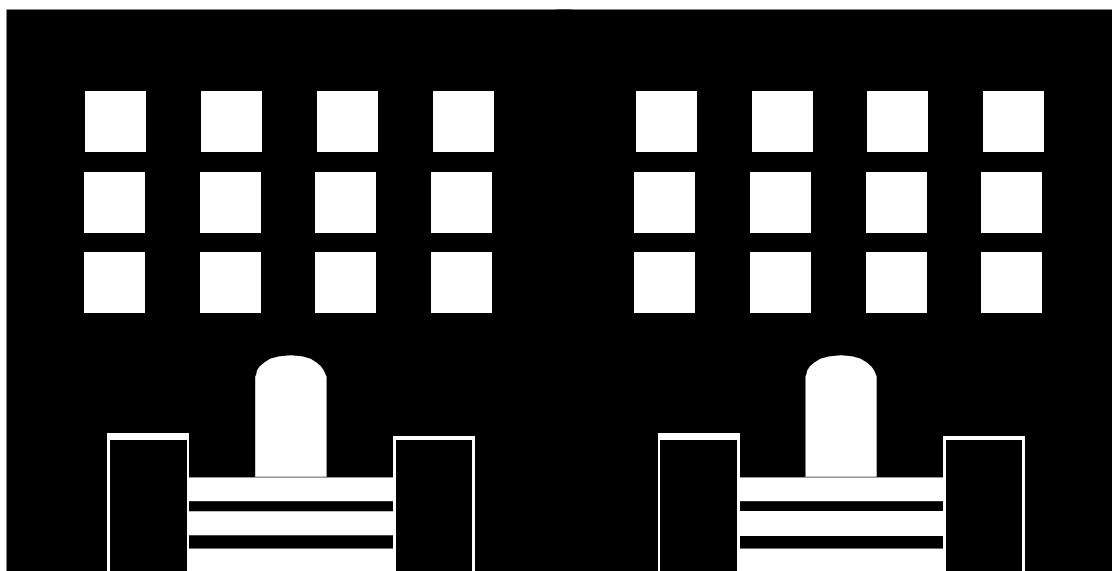

Source: EMPower Plus book Everyday Number Sense: Mental Math and Visual Models

Pictures and Numbers

Choose one picture from this page and one from the next page. For each, find the total number of objects in the picture, but don't count one by one. Write down two or more ways to find the total.

1. Soda Cans



2. Fingers

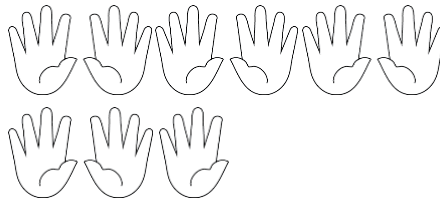

3. Heads

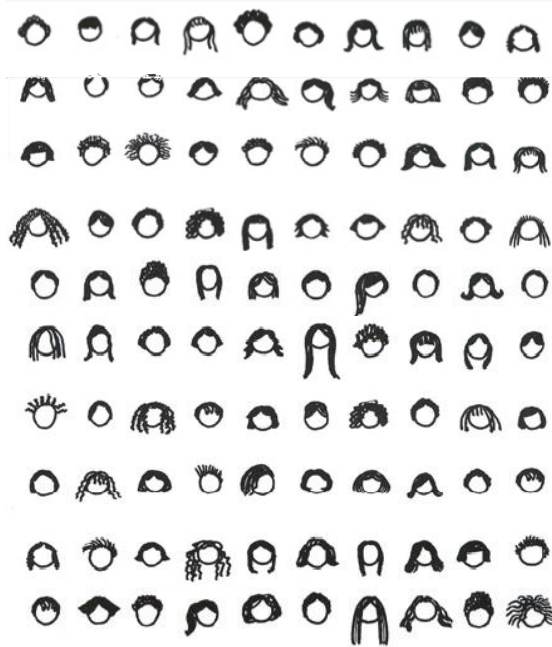

Reprinted with permission of *World Education*

4. Stamps



5. Chocolates

3. Sketch another arrangement. If you did not try arranging by 10's, try that now.

4. Write an expression that shows how you found the total amount without counting each item.

Garden Pathway

Valerie and Rebecca own a landscaping business. A customer wants them to install a garden and a pathway made of square tiles surrounding it. This is the picture the customer provided.

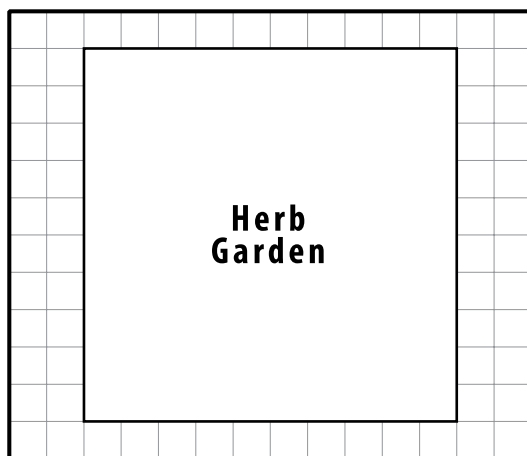

Each woman saw the math differently. Of course, they didn't count each tile! Show two different ways that Valerie and Rebecca could have figured out the number of tiles.

1. First way:

2. Second way:

Source: EMPower Plus book Everyday Number Sense: Mental Math and Visual Models

Expressions, Arrays, and Stories

Part 1

Circle the expressions that do not match the picture.

Reminder: Parentheses indicate multiplication or tell you to do the operation inside them first.

1. $10 + 10 + 3$

$3 \times 3 + 10$

$10 \times 2 + 3$

$3 + 2(10)$

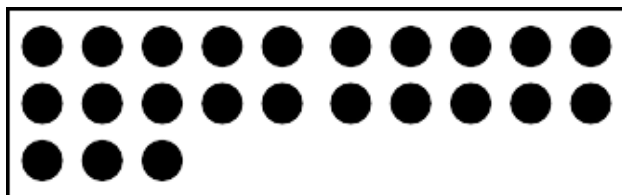

2. $3 \times 10 + 7$

$10 + 10 + 10 + 7$

$3(10 + 3)$

$4 \times 7 - 3$

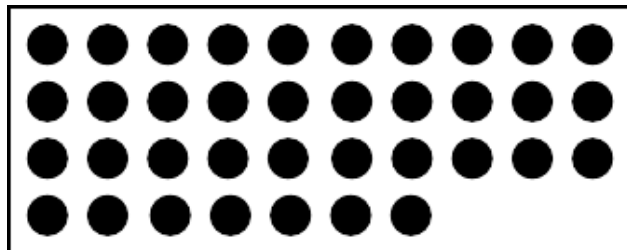

3. $5 + 5 + 5 + 5 + 5$

$5(5)$

$5 \times 5 + 5 + 5 + 5$

5^2

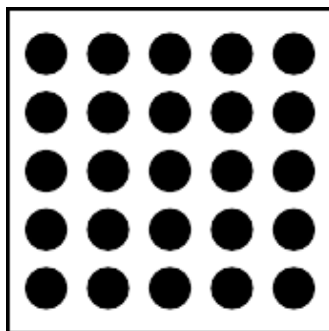

Part 2

Match each story to one of the pictures above.

4. Zippy and four friends combine their money. Each person gives the same amount, \$5.

Array _____

5. Zippy and two friends want to buy a gift for their teacher. The two friends can spend \$10 each. Zippy has \$3.

Array _____

6. Zippy and three friends order take-out. Everybody chips in \$10 but Zippy. He is \$3 short.

Array _____

Source: EMPower Plus book Everyday Number Sense: Mental Math and Visual Models

How Do You See It?

For each picture below, give the total number of shapes or coins, *without counting one by one*.

Circle the groups you see in each picture. Write two different expressions to show how you could find the total.

1. Circle the groups you see in each picture as you figure out the total. Write two expressions that describe what you see.



Expression 1: _____ Expression 2: _____



Expression 1: _____ Expression 2: _____

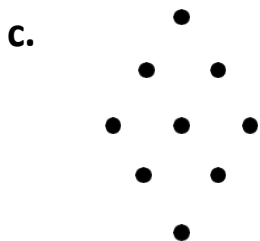

Expression 1: _____ Expression 2: _____

2. Show with words or an expression how you found the total number of tiles.

a.

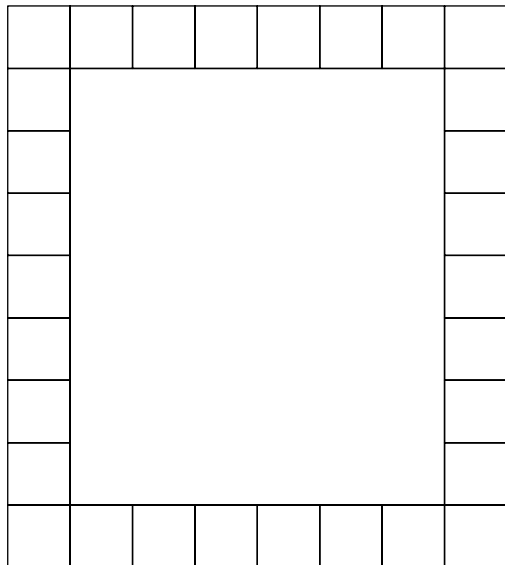

Words/Expression:

b. Show with words or an expression how you could find the total another way.

Source: EMPower Plus book Everyday Number Sense: Mental Math and Visual Models

Language for Sharing Your Thinking

The way I see it is...

I see ___ groups of ___

Another way to see it is...

My expression is...

My strategy was to...

I think they saw it this way...

One thing I tried that didn't work...

I am wondering...

I noticed that...

I am confused about...

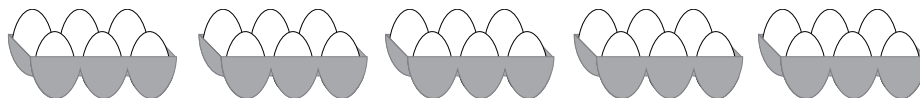
Exit Ticket/Homework: Cartons of Eggs

1. Without counting each egg, how many do you see?
2. How did you think of your answer?
3. List with words and numbers each step you took mentally or on paper to find the total.
4. Write another expression to show how you could count the eggs.



Test Practice

1. Which of the following expressions might be used to count the cookies on the tray?

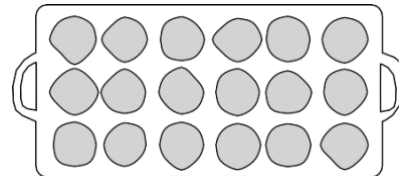

A. $6 + 6 + 6$ B. 6×3 C. 6×6

- (a) A only
(b) B only
(c) C only
(d) A and B
(e) A and C

2. Select the expression that is *not* equivalent to the rest of the expressions.

- (a) $36 + 4(5)$
(b) $4(9) + 20$
(c) $3(12) + 20$
(d) $4(9) + 4(6)$
(e) $2(18) + 2(10)$

3. The mayor wants all of the front windows on the city’s eight libraries to be cleaned. Charlie’s Windows charges \$6 per window for cleaning. Which of the following expressions shows how much Charlie’s Windows will charge the city?

- (a) $6(3 \times 4)$
- (b) $6 + (3 \times 4)8$
- (c) $8(12 + 6)$
- (d) $6(4 \times 12)$
- (e) $6(3 \times 4 \times 8)$

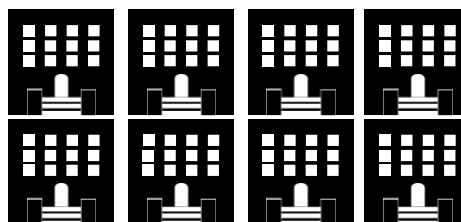

4. Lois enters a party room and sees people sitting at round tables. Eight people are seated at each of 12 tables and five people at each of two other tables. How many people does Lois see?

Source: EMPower Plus book Everyday Number Sense: Mental Math and Visual Models

Name _____ Date _____

Multiplication Concepts: Unit 3, Equivalent Expressions

| Objective | My Progress (Struggling, Learning, Mastery) |
|---|--|
| I can express repeated addition as multiplication. | |
| I can use arrays to model multiplication expressions and scenarios. | |
| I can find equivalent expressions for an array. (Array of the Day) | |
| I can write expressions equal to a target number. (Number of the Day) | |
| I can decide if a math sentence is true or false. (Two Truths and a Lie) | |

UNIT 4: Breaking into Parts

Financial Literacy: Small Costs That Add Up

1. Jayla loves to get a coffee on her way to work. She pays about \$3 for her favorite coffee drink. She does this 4 times per week.



How much does Jayla usually spend on coffee in a month?

2. Jayla usually spends about _____ on coffee in a month.

Write an addition expression and a multiplication expression for how much she would spend on coffee in 12 months (1 year).

| Addition Expression | Multiplication Expression |
|---------------------|---------------------------|
| | |

3. Solve for the total, using a strategy that makes sense to you.

Vocabulary List for This Unit

| Word | Definition | Example |
|------|------------|---------|
| | | |
| | | |
| | | |
| | | |

| Word | Definition | Example |
|------|------------|---------|
| | | |
| | | |
| | | |
| | | |

Breaking Up Arrays

One way to show multiplication is with a **rectangular array**.

1. Look at this example:

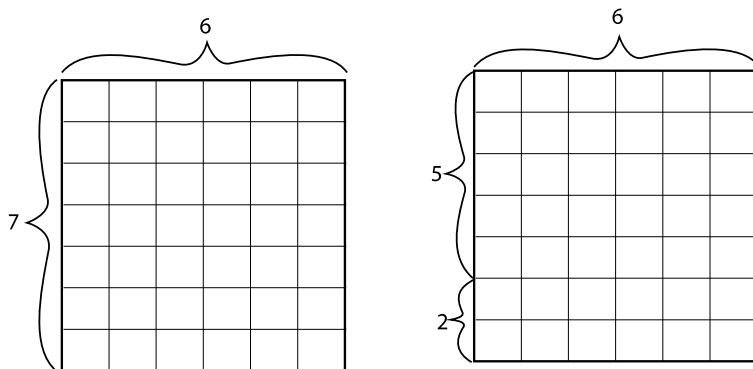

a. Explain in words what you see happening.

b. Explain in mathematical symbols what is happening.

2. Below is an 8×9 array.

a. Break it up into a new multiplication problem.

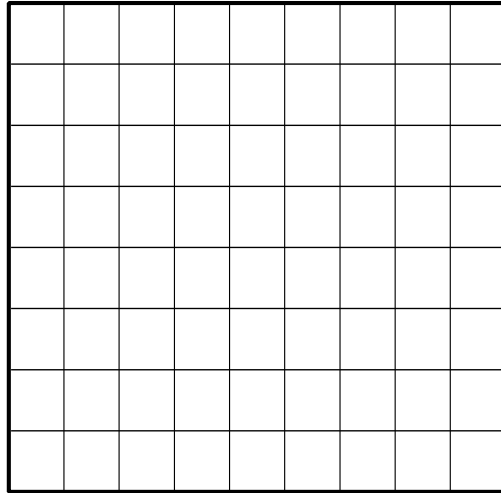

b. Explain in words what you see happening.

c. Explain using mathematical symbols what is happening.

2. Below is a 5×12 array.

a. Break it up into a new multiplication problem.

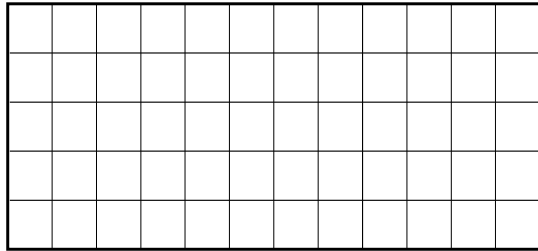

b. Explain in words what you see happening.

c. Explain using mathematical symbols what is happening.

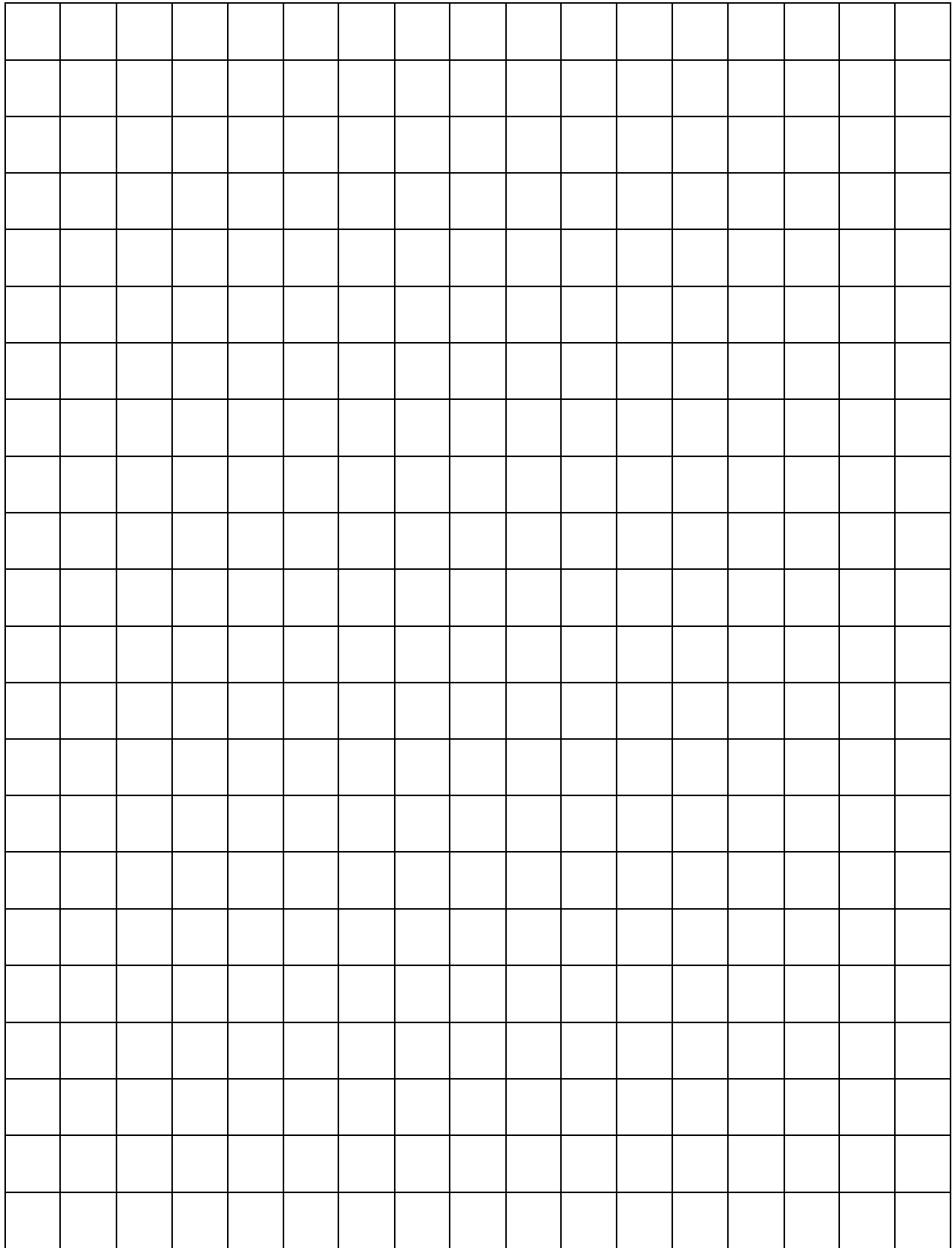

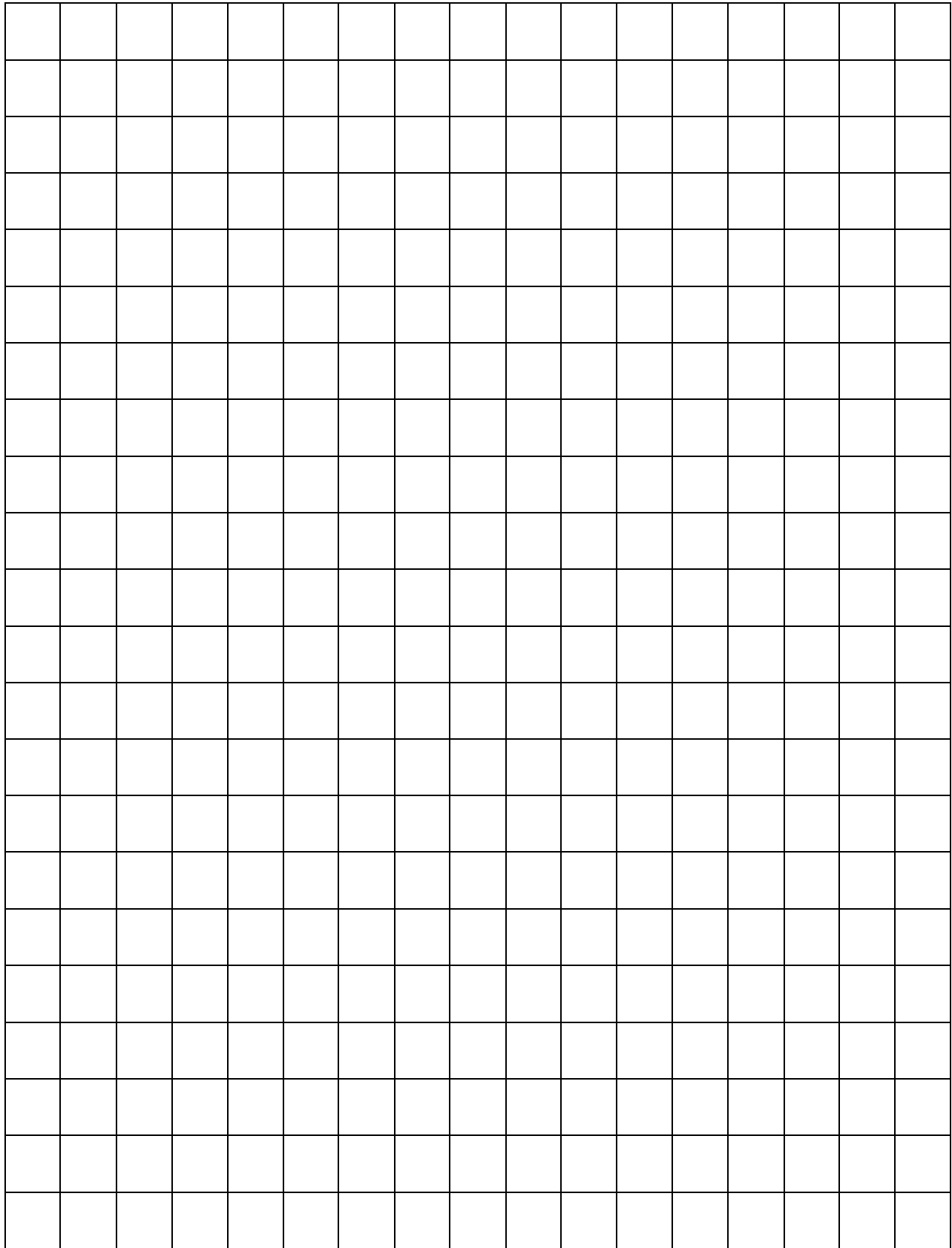

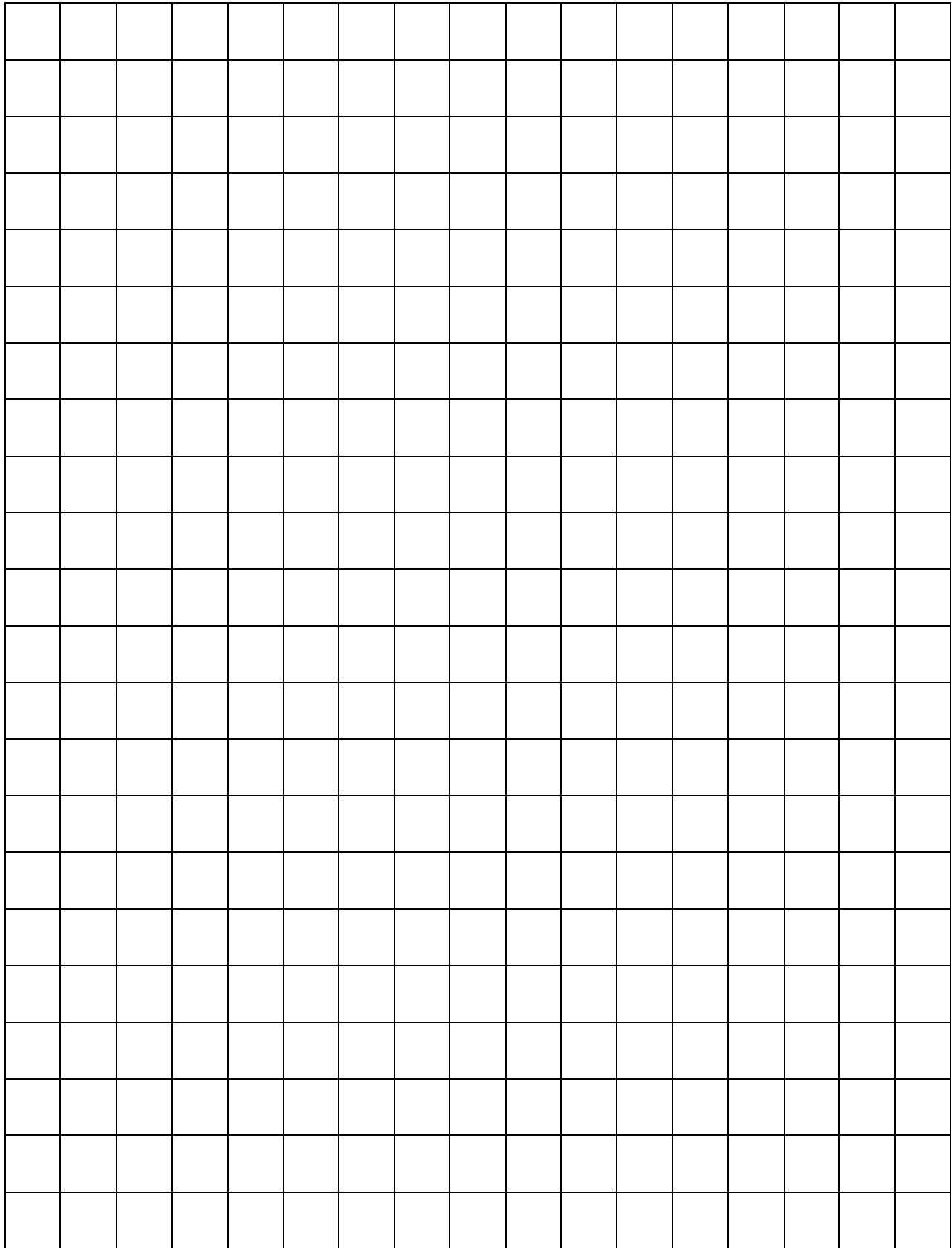

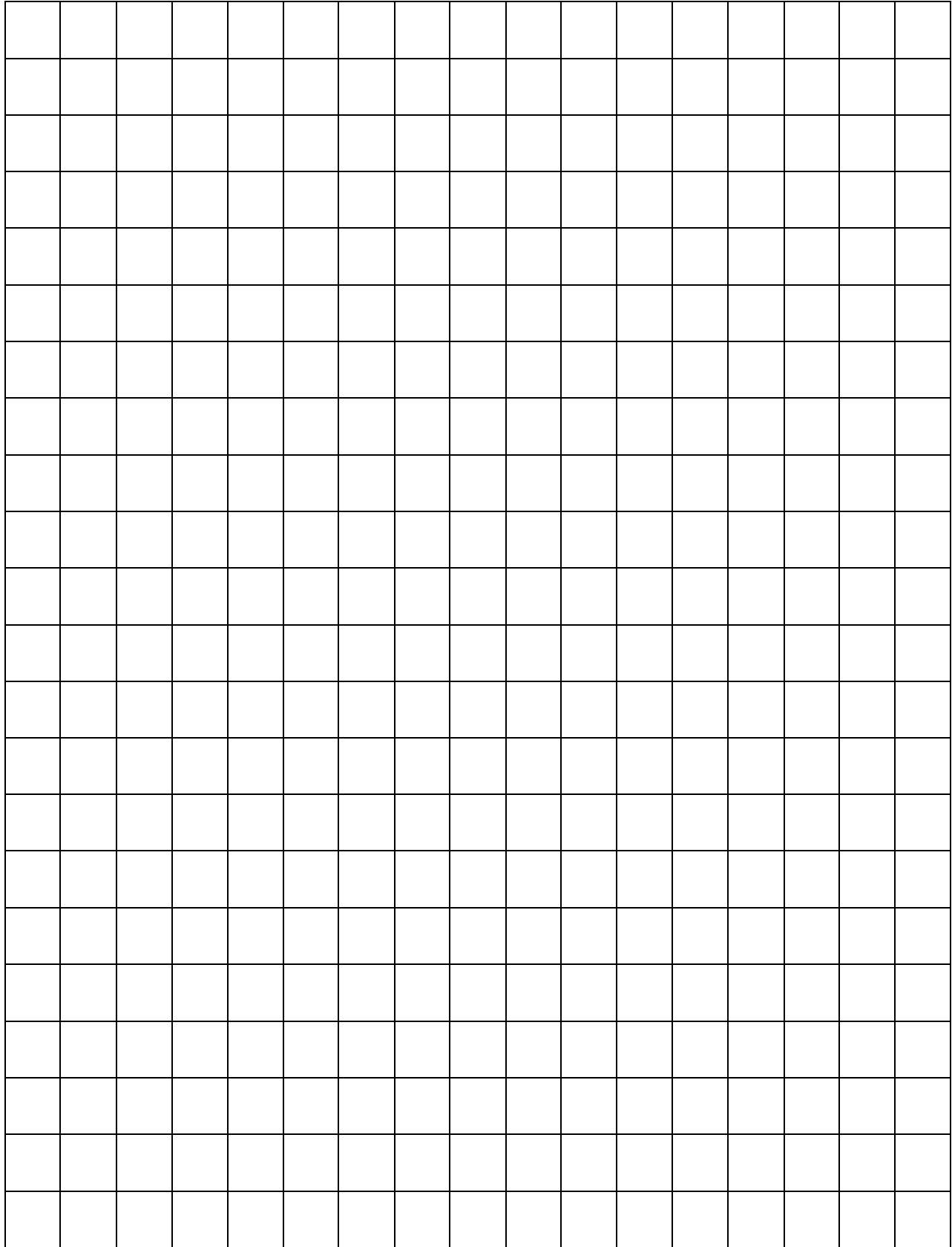

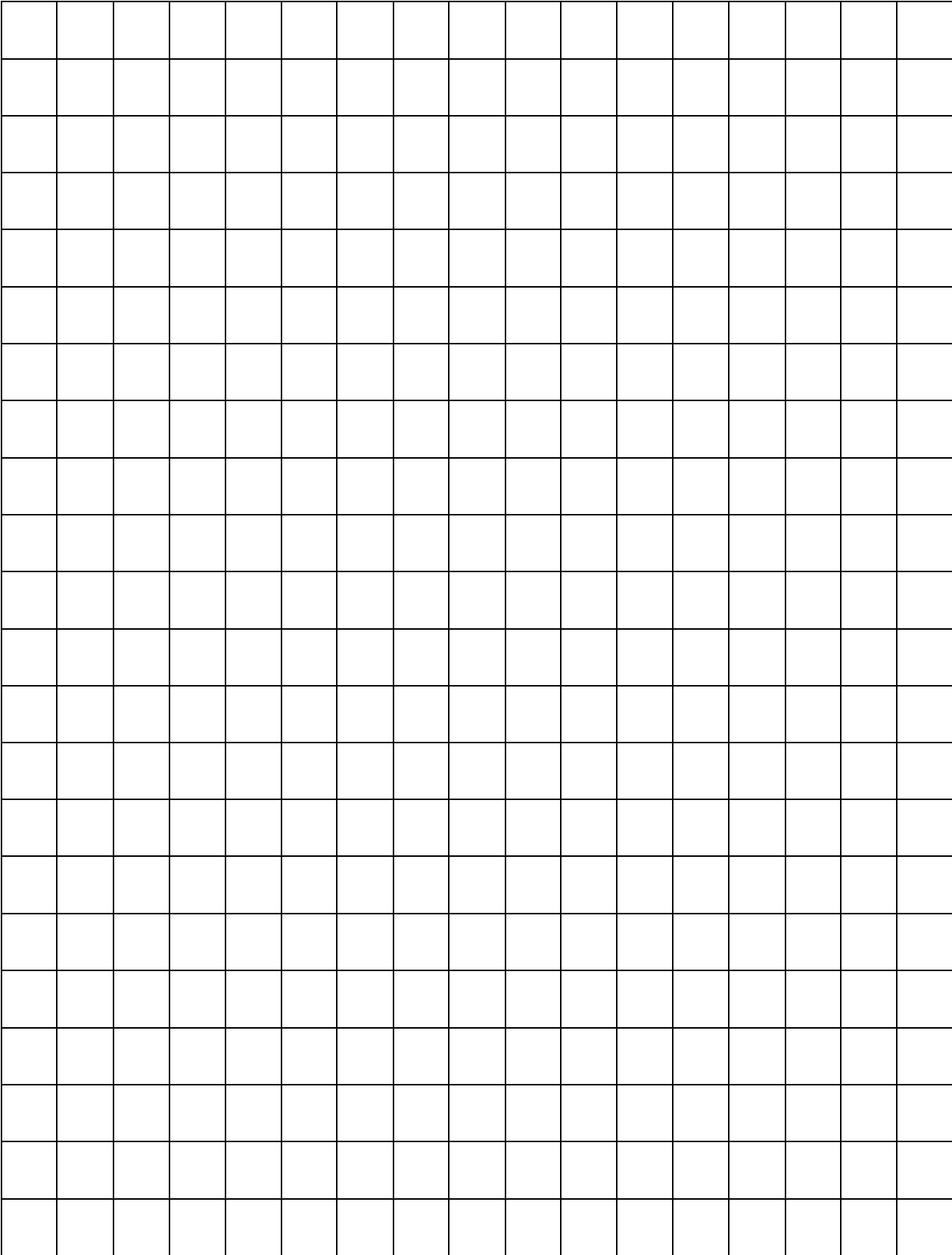

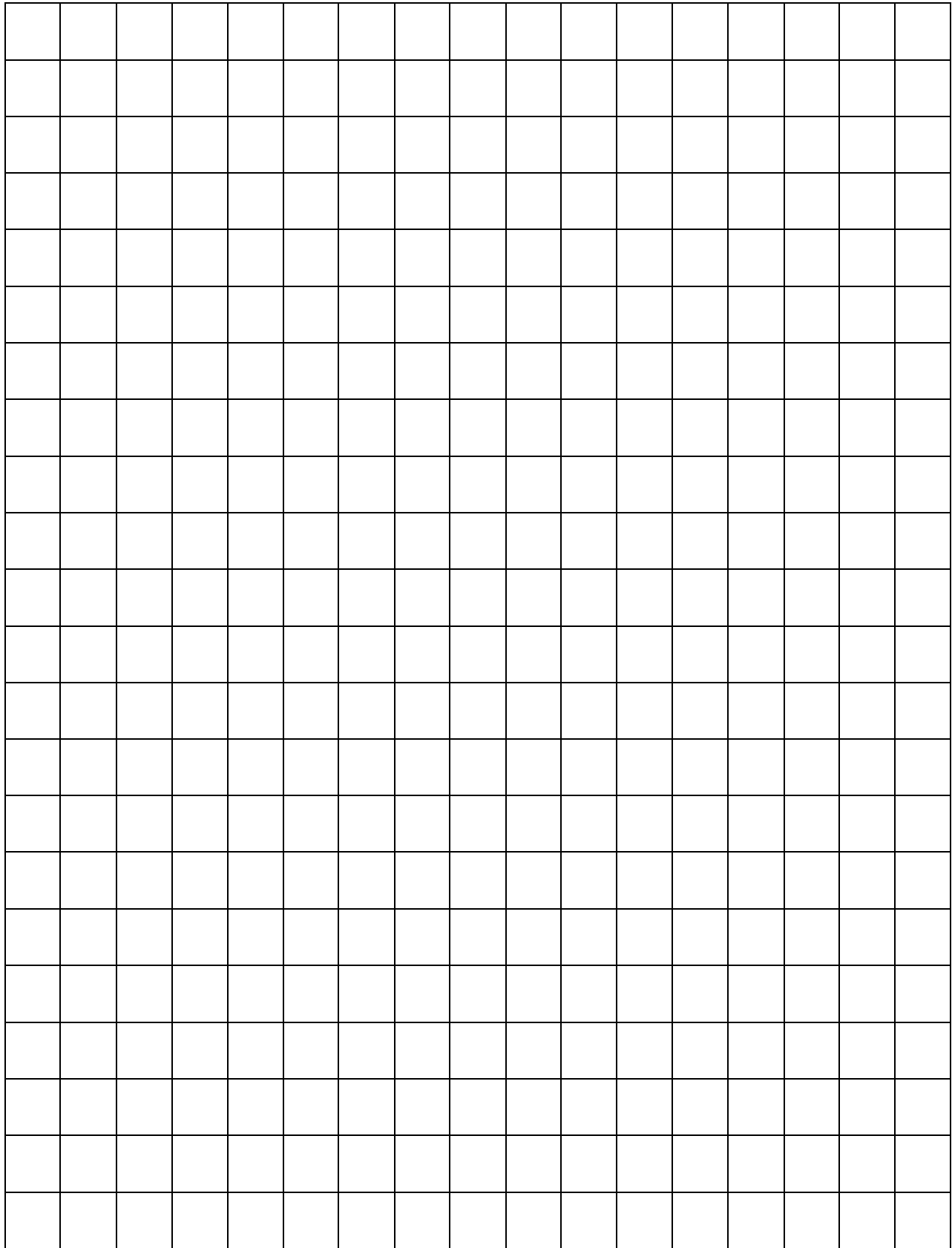

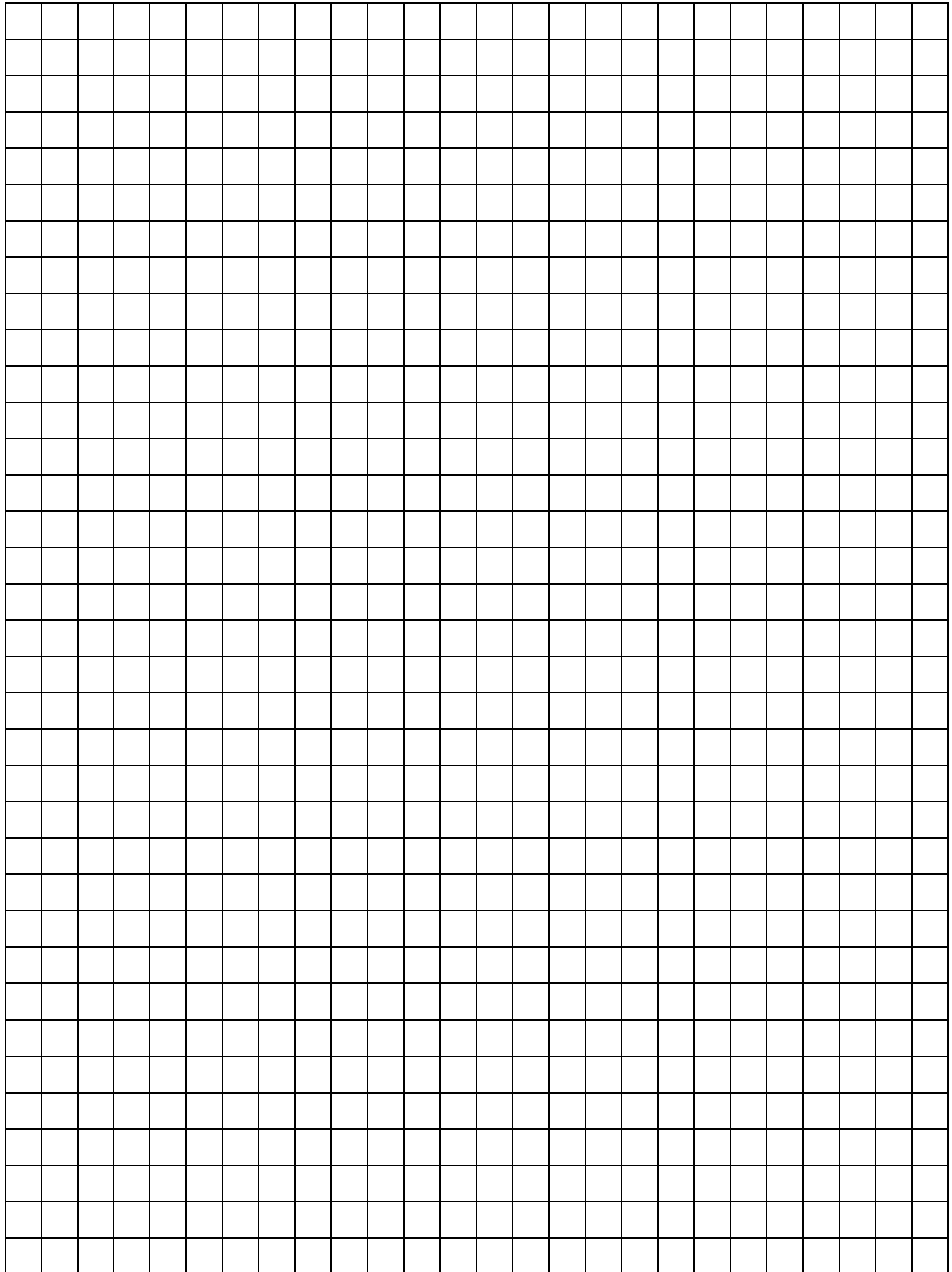

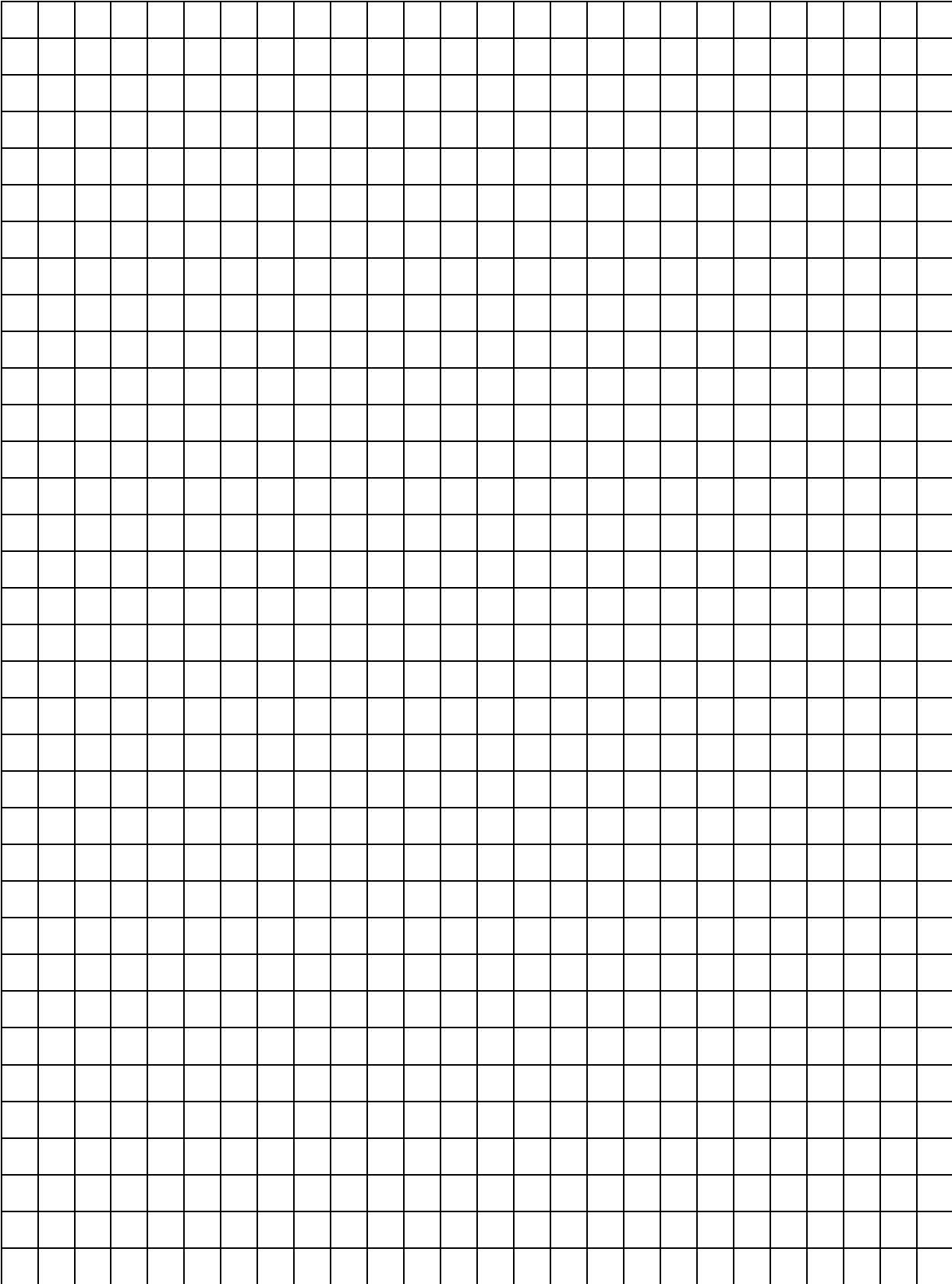

Finding Missing Factors

Use the Partial Products Finder or grid paper to help you find the missing number.

A) $6 \times 7 = 6 \times 4 + 6 \times \underline{\quad}$

B) $9 \times 8 = \underline{\quad} \times 8 + 4 \times 8$

C) $\underline{\quad} \times 7 = 2 \times 7 + 5 \times 7$

D) $6 \times 7 = 5 \times 7 + \underline{\quad} \times 7$

E) $7 \times \underline{\quad} = 5 \times 6 + 2 \times 6$

F) $9 \times 9 = 5 \times 9 + \underline{\quad} \times 9$

G) $8 \times 7 = \underline{\quad} \times 7 + 5 \times 7$

Performance Task: Graduation Seating

1. Design an arrangement for 60 chairs in the space available.
2. Mark where you will put the chairs on the diagram provided (you can use the side with the grid or the blank side.)
3. Write an expression that represents your array and show how it is equal to 60.

Things to consider:

- Everyone must be able to see the podium.
- Graduates need to be able to process in from the door to the podium.
- 15 chairs are for the graduates; think about where you want them to sit.

Rubric

| Criteria | Outstanding | Good | Needs Support |
|---------------------------|---|--|---|
| Real world considerations | The plan takes all real world considerations into account: everyone can see the podium and graduates and others can easily get in and out. | The plan takes some of these considerations into account, but one or more issues may come up if this was really carried out. | The plan is not realistic and has multiple problems. |
| Math Expression | The math expression is accurate, uses algebraic notation (parentheses for multiplication), and clearly reflects the way that the chairs are arranged. | The math expression is accurate, but uses arithmetic notation and does not clearly reflect the arrangement. | The math expression is inaccurate or uses notation incorrectly. |

Community Room

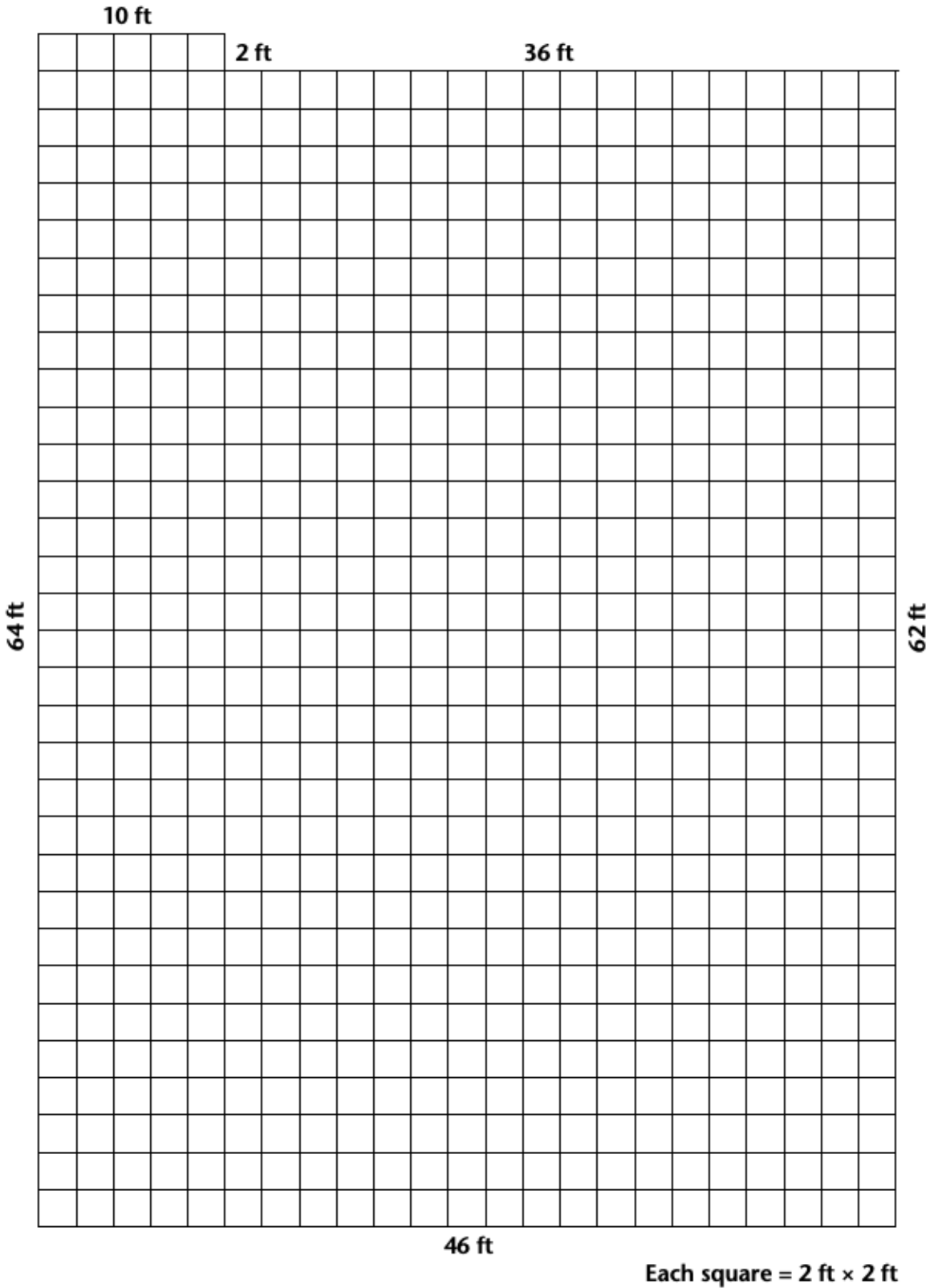

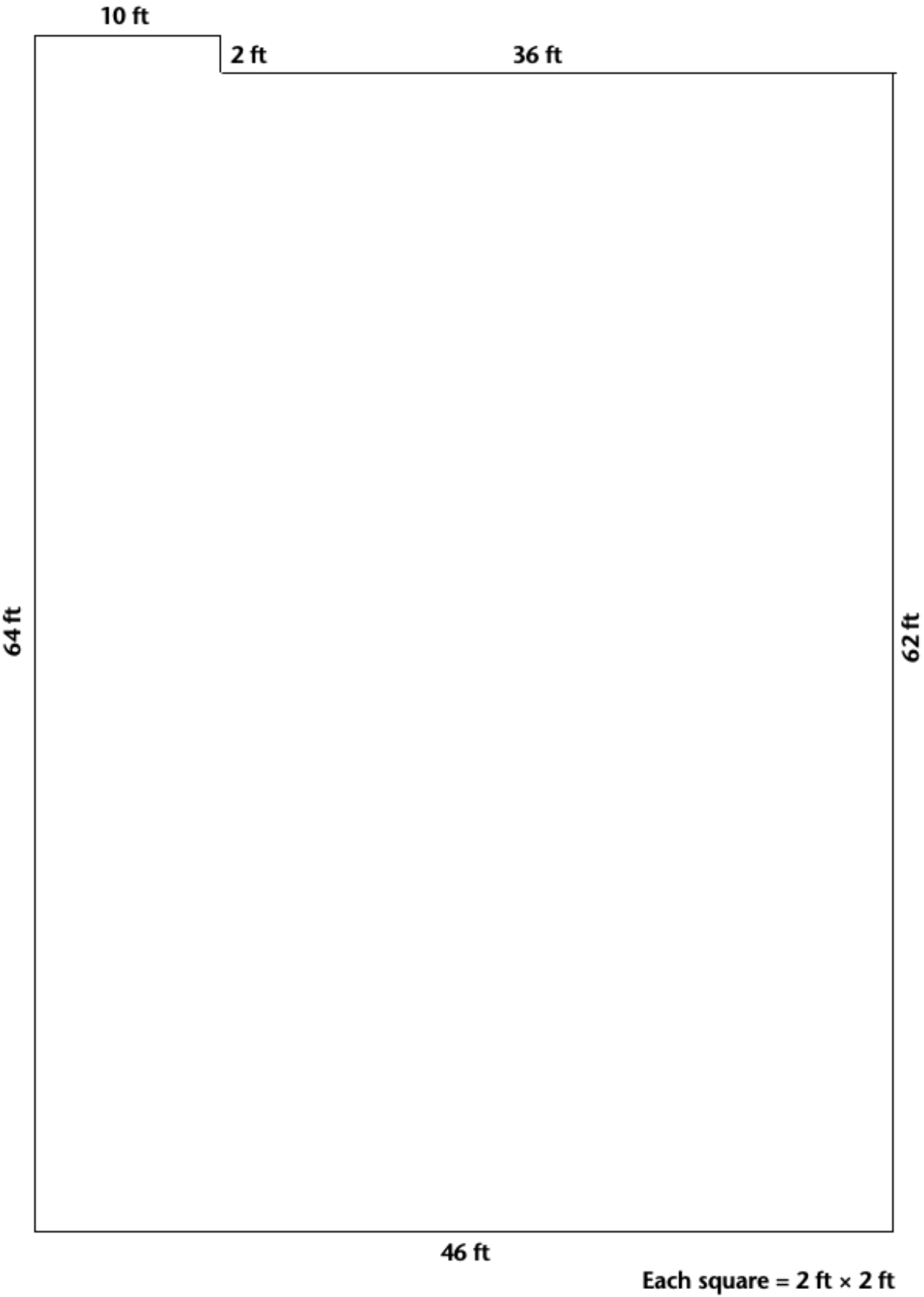

Talking about Arrays



Write three sentences to describe the array of chocolates above.

Useful words:

rows columns ___groups of___
factors product equation

Name _____ Date _____

Multiplication Concepts: Unit 4, Breaking into Parts

| Objective | My Progress (Struggling, Learning, Mastery) |
|---|--|
| I can break multiplication problems into smaller parts with an array. | |
| I can break multiplication into smaller parts with numbers. | |
| I can find equivalent expressions for an array. (Array of the Day) | |
| I can write expressions equal to a target number. (Number of the Day) | |
| I can decide if a math sentence is true or false. (Two Truths and a Lie) | |

UNIT 5: Application Project

Financial Literacy: Placing an Order



Discussion questions:

When have you had to place an order?

How have you placed an order?

- On paper
- Over the phone
- Online

If you were ordering office supplies for your workplace, what information would you need to know?

Vocabulary List for This Unit

| Word | Definition | Example |
|------|------------|---------|
| | | |
| | | |
| | | |
| | | |

| Word | Definition | Example |
|------|------------|---------|
| | | |
| | | |
| | | |
| | | |

Price/Quantity Slides



Five boxes of 24 crayons are arranged in two rows: three in the top row and two in the bottom row. Each box is green and yellow with the number '24' and the word 'CRAYONS' prominently displayed. A price tag in the bottom right corner of the slide indicates the cost.

\$3 per box

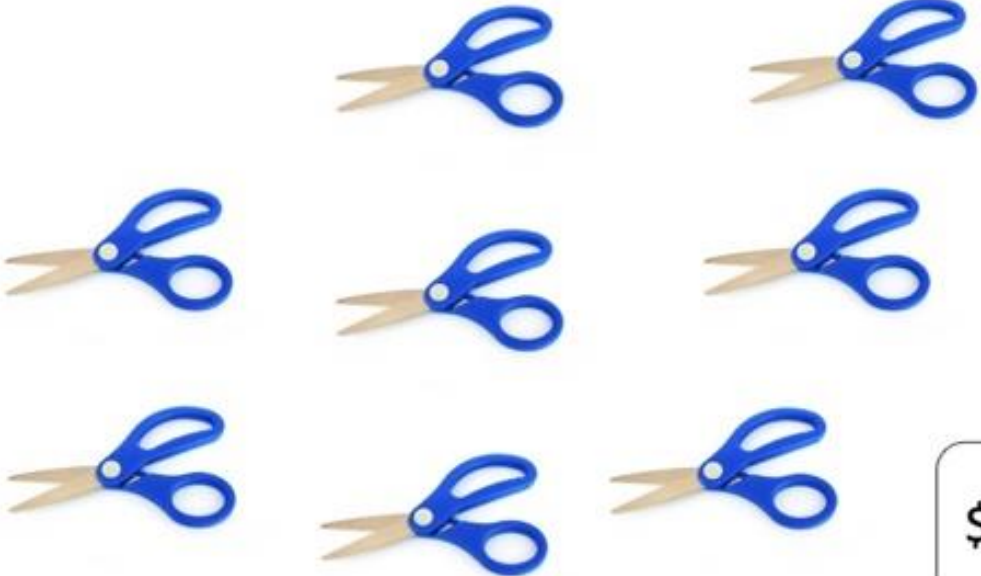

Eight pairs of blue-handled scissors are arranged in three rows: two in the top row, three in the middle row, and three in the bottom row. A price tag in the bottom right corner of the slide indicates the cost.

\$2 each

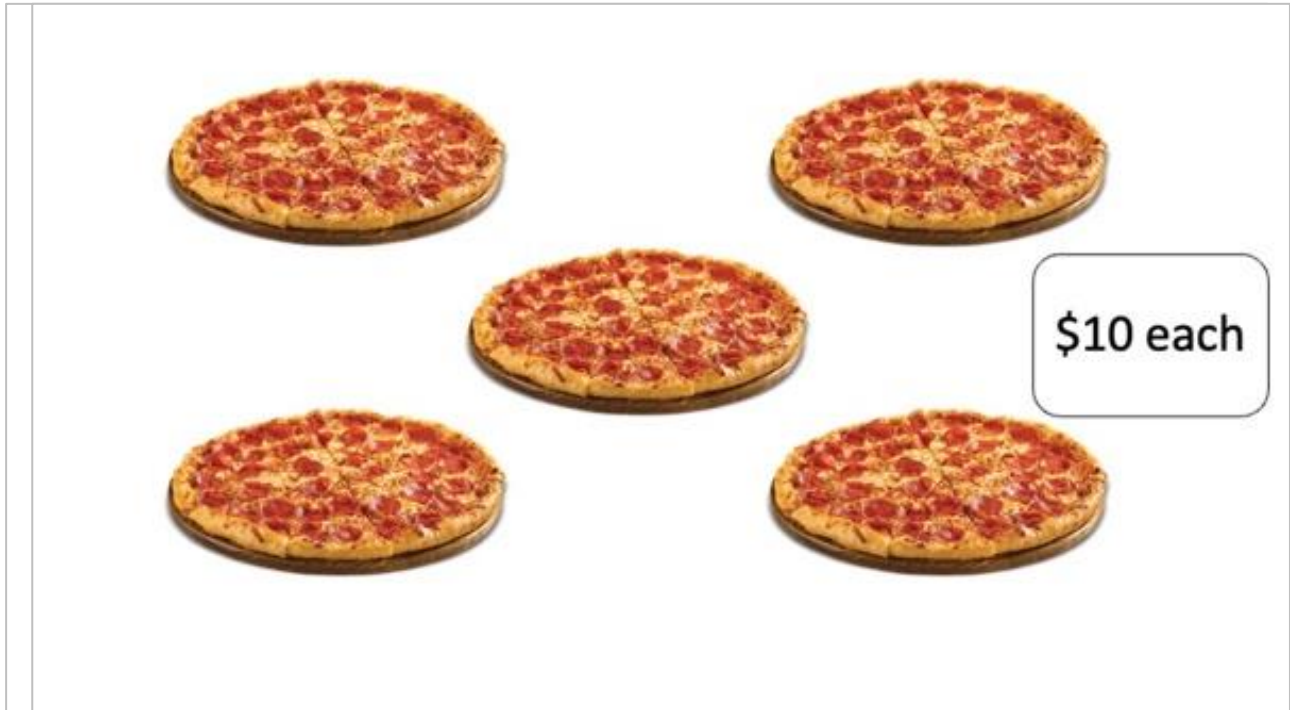



\$5 each



\$3 each

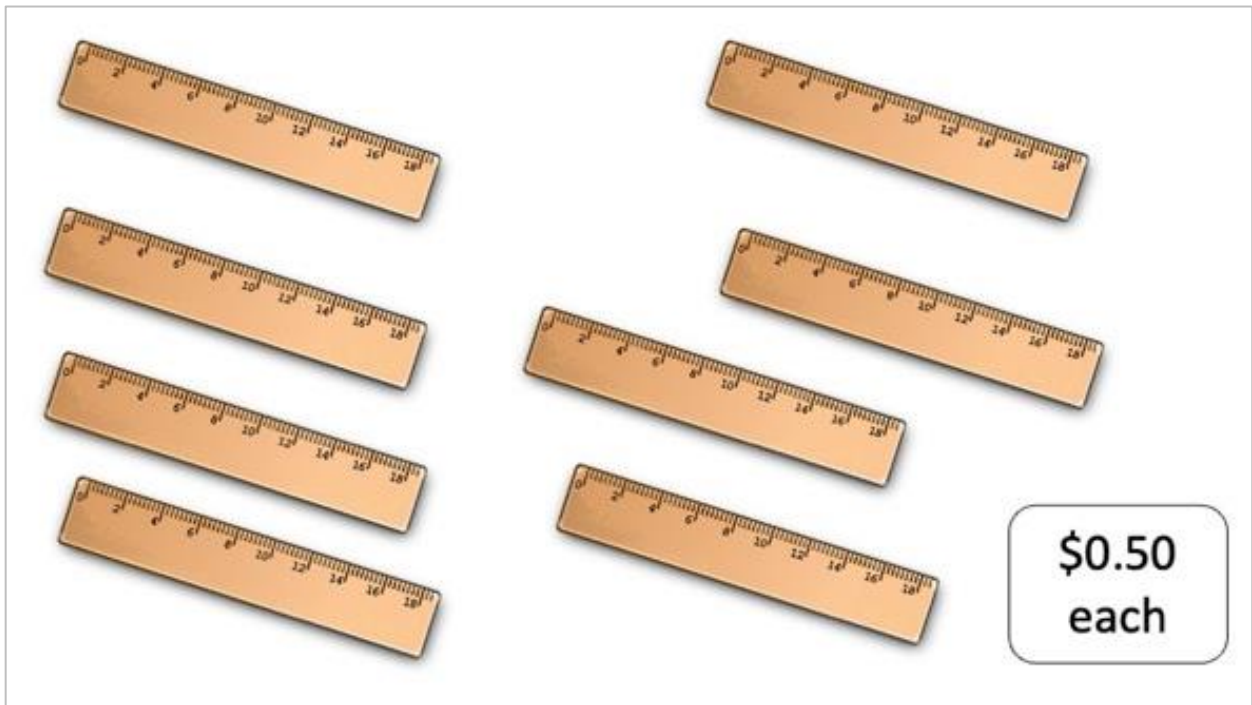

Sample Invoice



Mel's Office Supplies

123 Main St
 notreal@gmail.com
 123-456-7890

INVOICE

Invoice No: #INV00001
Invoice Date: 11/11/11
Due Date: 12/12/12

| DESCRIPTION | QUANTITY | UNIT PRICE | TOTAL |
|------------------------|----------|------------|-----------|
| Staplers | 4 | \$ 5.00 | \$ 20.00 |
| Inkjet Printers | 2 | \$ 100.00 | \$ 200.00 |
| Printing paper (reams) | 10 | \$ 4.00 | \$ 40.00 |
| Office Chairs | 3 | \$ 30.00 | \$ 90.00 |
| | | | |
| | | | |
| | | | |
| | | | |
| | | | |

| | | |
|-------------------------------|----|---------------|
| SUBTOTAL | \$ | 350.00 |
| DISCOUNT | \$ | - |
| SUBTOTAL LESS DISCOUNT | \$ | 350.00 |
| TAX RATE | | 0.00% |
| TOTAL TAX | \$ | - |
| SHIPPING/HANDLING | \$ | - |
| Balance Due | \$ | 350.00 |

Thank you for your business!

Fill Out the Invoice (practice)



Mel's Office Supplies

123 Main St
notreal@gmail.com
 123-456-7890

INVOICE

Invoice No: #INV00001
Invoice Date: 11/11/11
Due Date: 12/12/12

| DESCRIPTION | | | |
|------------------------|--|-----------|--|
| Staplers | | \$ 5.00 | |
| Inkjet Printers | | \$ 100.00 | |
| Printing paper (reams) | | \$ 4.00 | |
| Office Chairs | | \$ 30.00 | |
| | | | |
| | | | |
| | | | |
| | | | |
| | | | |
| | | | |

| | | |
|-------------------------------|----|-------|
| SUBTOTAL | | |
| DISCOUNT | \$ | - |
| SUBTOTAL LESS DISCOUNT | \$ | - |
| TAX RATE | | 0.00% |
| TOTAL TAX | \$ | - |
| SHIPPING/HANDLING | \$ | - |
| Balance Due | \$ | - |

Thank you for your business!

BBQ Invoice Project

Your job is to plan a party for 10 people. Your total budget is \$110. You don't have to spend all of the money, but you can't go over.

Decide how many of each to order from the catering company and fill out the invoice.

| Catering | Quantity | Price | Total Cost |
|-------------------------------------|-----------------|--------------|-------------------|
| Roast chicken (per person) | | \$9.00 | |
| Veggie burger (per person) | | \$7.00 | |
| Steak (per person) | | \$11.00 | |
| Unlimited soda (per person) | | \$1.00 | |
| 2 drinks, beer/wine (per person) | | \$5.00 | |
| | | | |
| Grand total | | | |

Rubric for BBQ Project

| Criteria | Outstanding | Good | Needs Support |
|---------------------------|---|---|---|
| Real world considerations | The invoice fits the budget and provides food and drink for all guests in a realistic way. | The invoice fits the budget and provides food for all guests. | The invoice is over budget and/or does not provide enough food for all guests. |
| Strategic Use of Tools | Mental math, paper and pencil, and calculators are all used strategically and efficiently to solve the problem. | Some thought given to using different tools. More than one tool used throughout the task. | No thought given to choosing tools strategically. Tools chosen are too laborious or rely exclusively on calculator without considering a way to check for reasonableness. |

Talking About Price and Quantity

Customer: How much do the notebooks cost?

Salesperson: The notebooks are \$3.99 **each**.

Customer: I would like to order 10 notebooks.

Salesperson: Ok, **10 notebooks at \$3.99 each**...that is \$39.90. Did you want to add anything else to your order?

Customer: Yes, I would like to order pens.

How much does a box of 20 pens cost?

Salesperson: Boxes of 20 pens are \$2.10 **per box**.

Customer: I'll take 3 boxes.

Salesperson: Ok, **3 boxes at \$2.10 per box is \$6.30** for the pens.
Your total is \$46.20.



Test Practice

1. Tom said he figured out the number of tiles needed for the floor of his kitchen with the equation $4 \times 8 + 2$. Which of the following arrangements shows a possible tile arrangement for Tom's kitchen?

A.

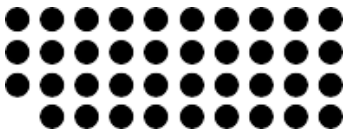

B.

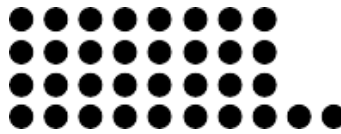

C.

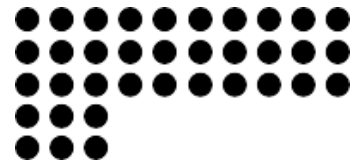

D.

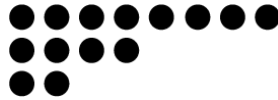

E.

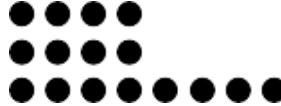

- (a) A
- (b) B
- (c) C
- (d) D
- (e) E

2. Every month, Marlene pays \$16 for basic local phone service. Most months she has no extra charge. This past year, she did have an extra charge of \$10 for one month. Which of the following expressions shows a way to find how much Marlene paid for her phone service this past year?

- (a) $12(\$10) + \16
- (b) $12(\$16) + \10
- (c) $12(\$16 + \$10)$
- (d) $\$16(12 + \$10)$
- (e) $\$16(\$10) + 12$

3. Eric charged 10 items last month on his credit card. Each item cost about \$25. When he received his bill, he noticed that he had a \$25 credit from a returned purchase made the previous month. What is the approximate amount of Eric's current bill?

- (a) \$60
- (b) \$175
- (c) \$225
- (d) \$250
- (e) \$275

4. Laila works at a daycare center. Each day she takes out four six-packs of juice for the toddlers. Each toddler gets one serving of juice. Today, three toddlers are not in school. Which of the following expressions shows the number of juices Sara will use today?

- (a) 4×6
- (b) $4(6) + 3$
- (c) $4(6) - 3$
- (d) $24 \div 6$
- (e) $24 \div 4$

Source: EMPower Plus book Everyday Number Sense: Mental Math and Visual Models

Name _____ **Date** _____**Multiplication Concepts: Unit 5, Application Project**

| Objective | My Progress (Struggling, Learning, Mastery) |
|---|--|
| I can complete an invoice, using multiplication to find the total cost. | |
| I can find equivalent expressions for an array. (Array of the Day) | |
| I can write expressions equal to a target number. (Number of the Day) | |
| I can decide if a math sentence is true or false. (Two Truths and a Lie) | |

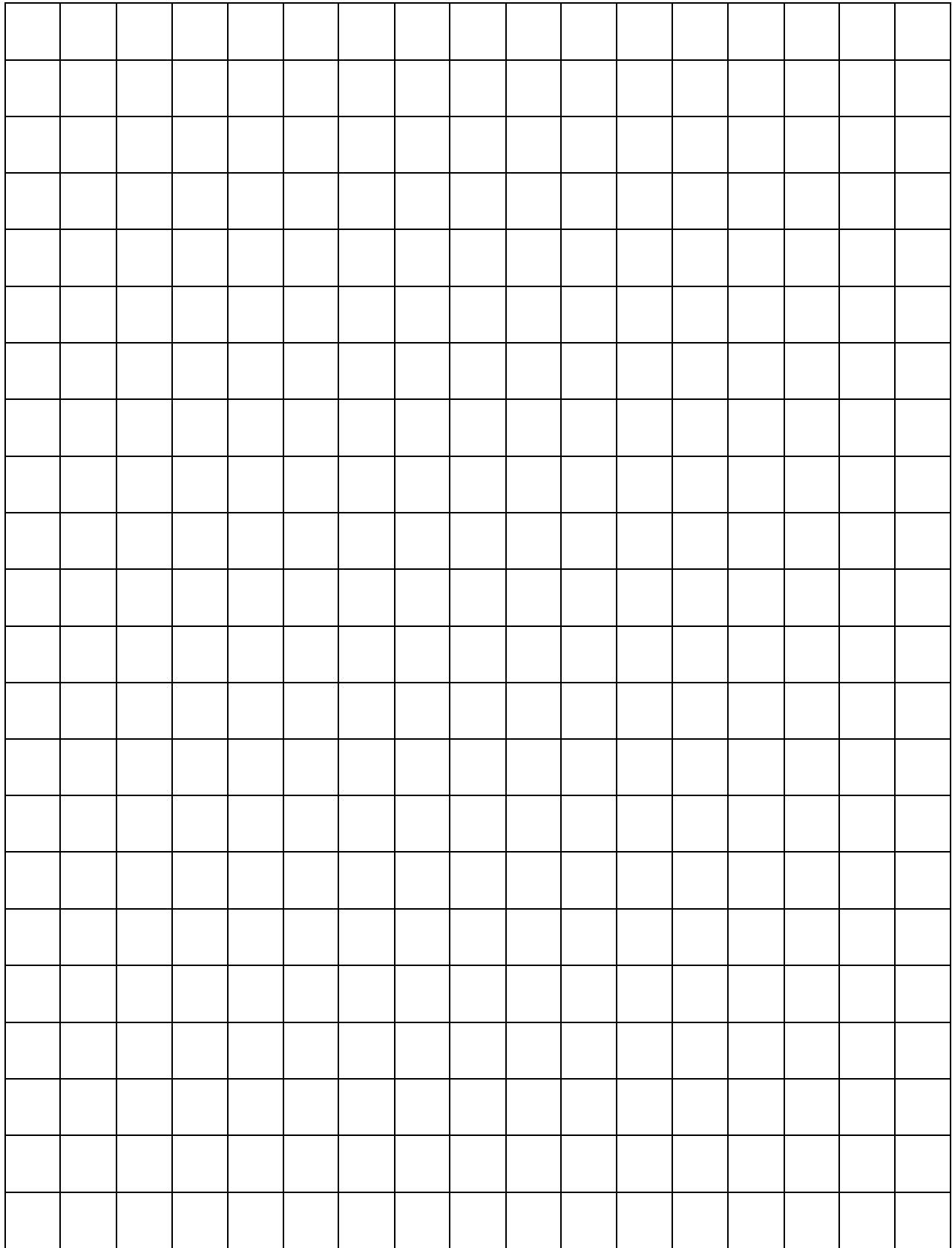

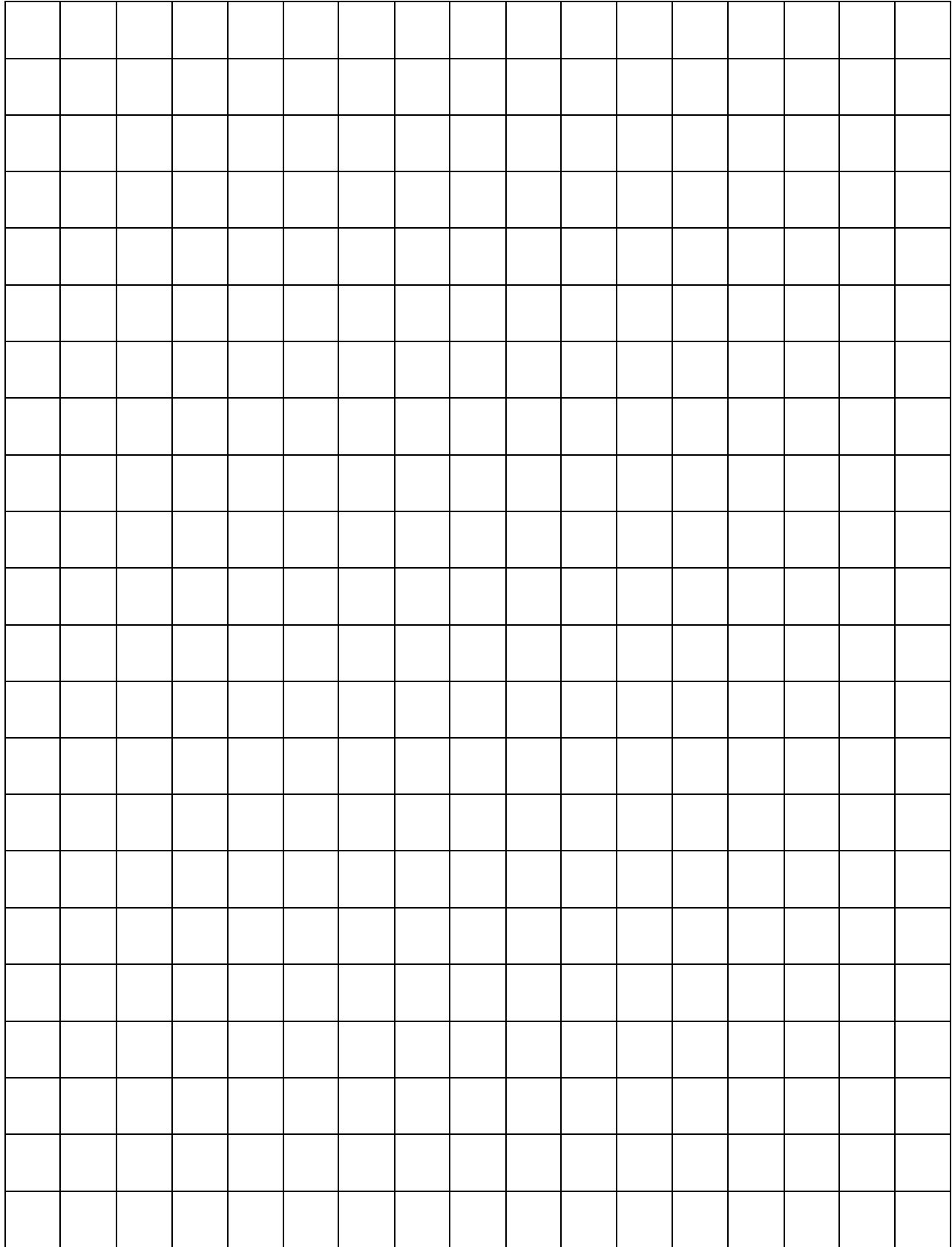

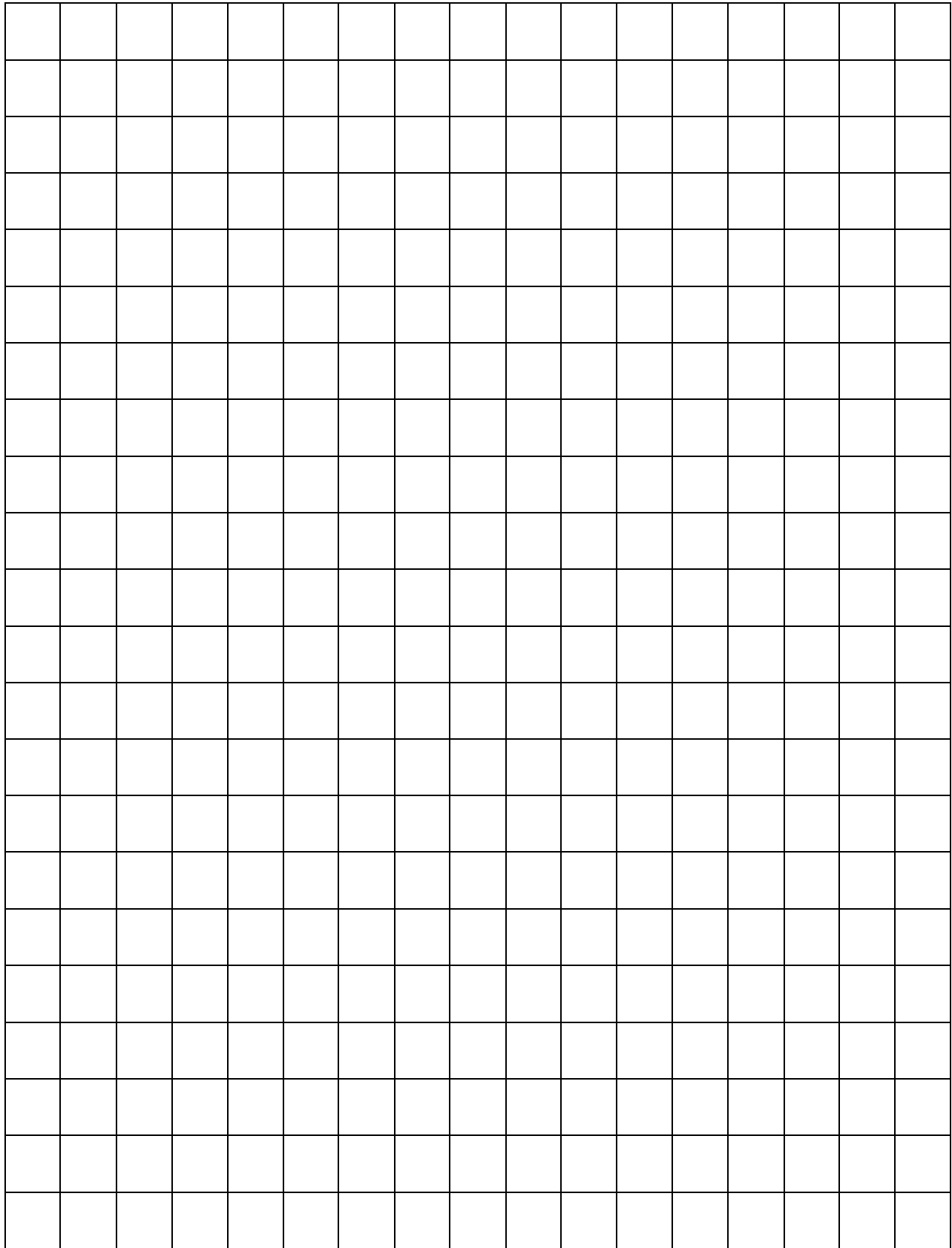

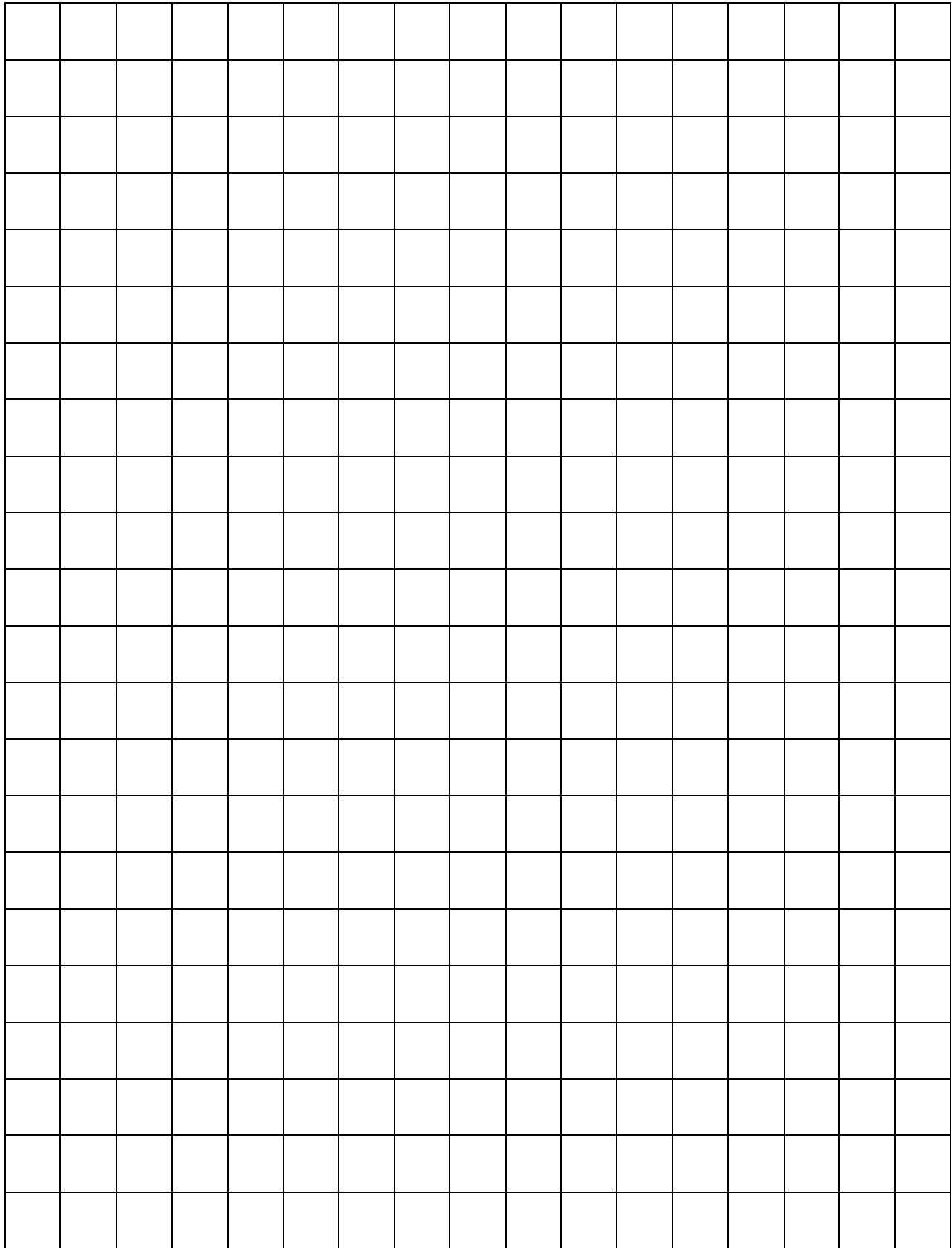

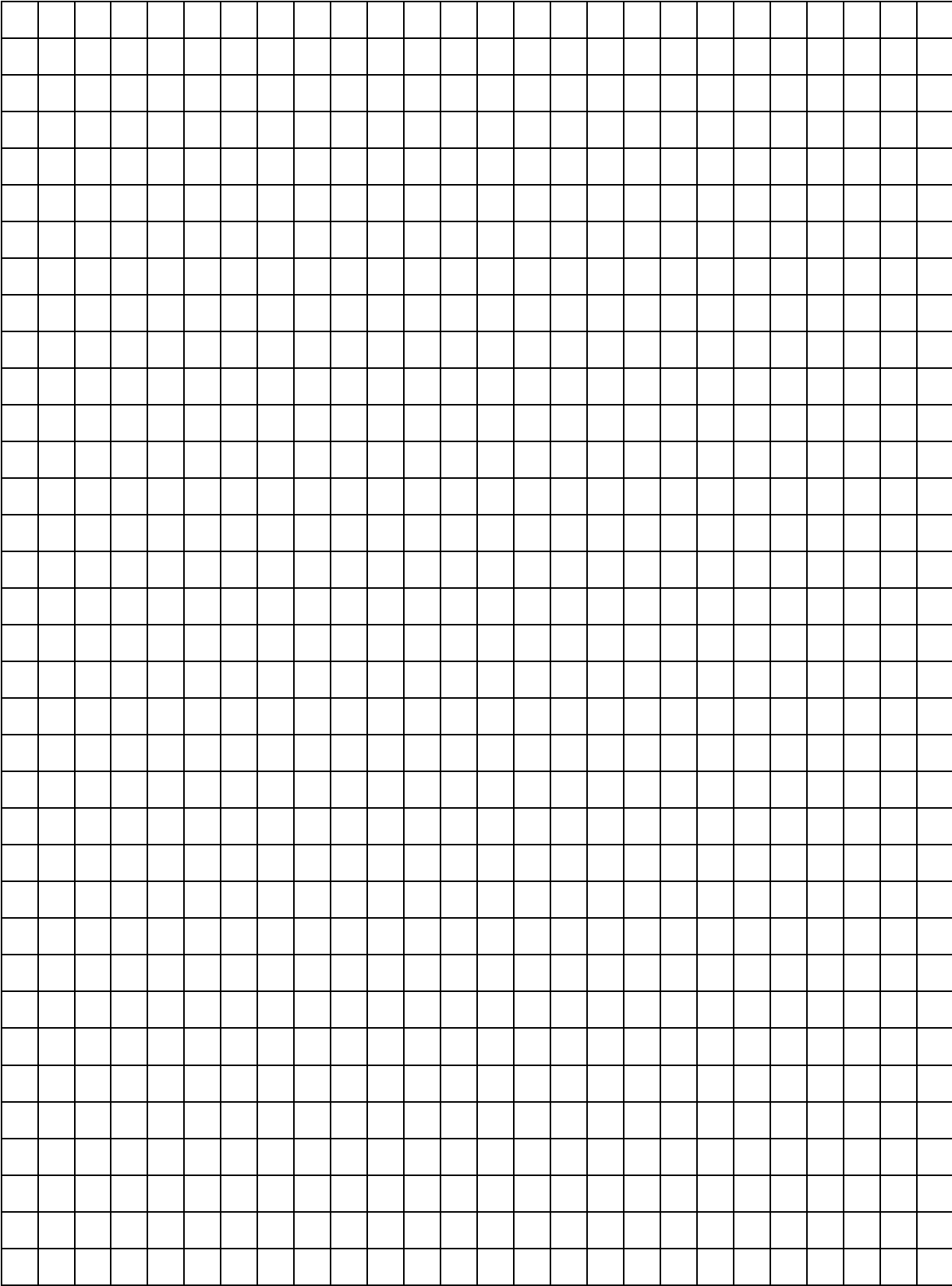

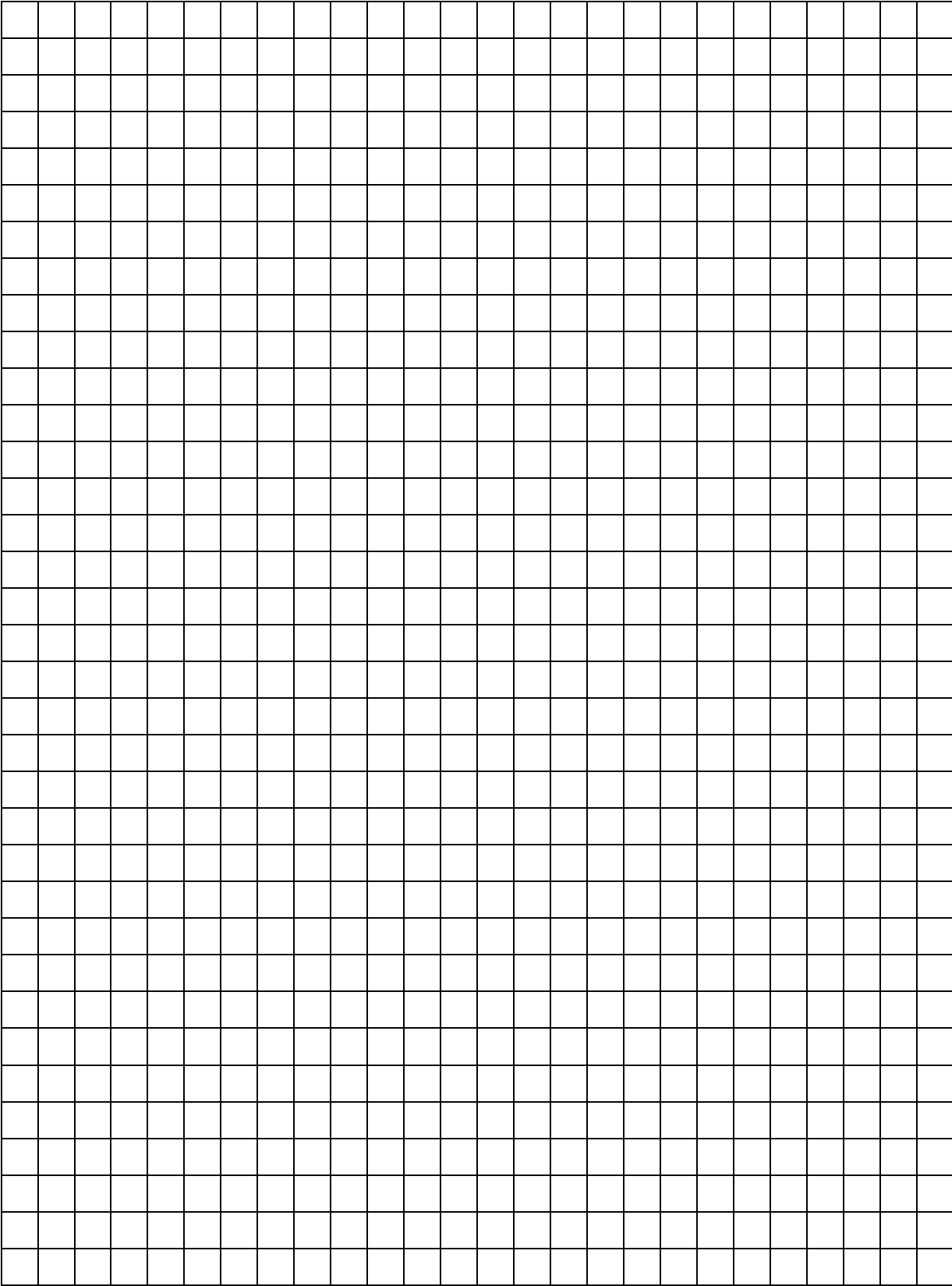

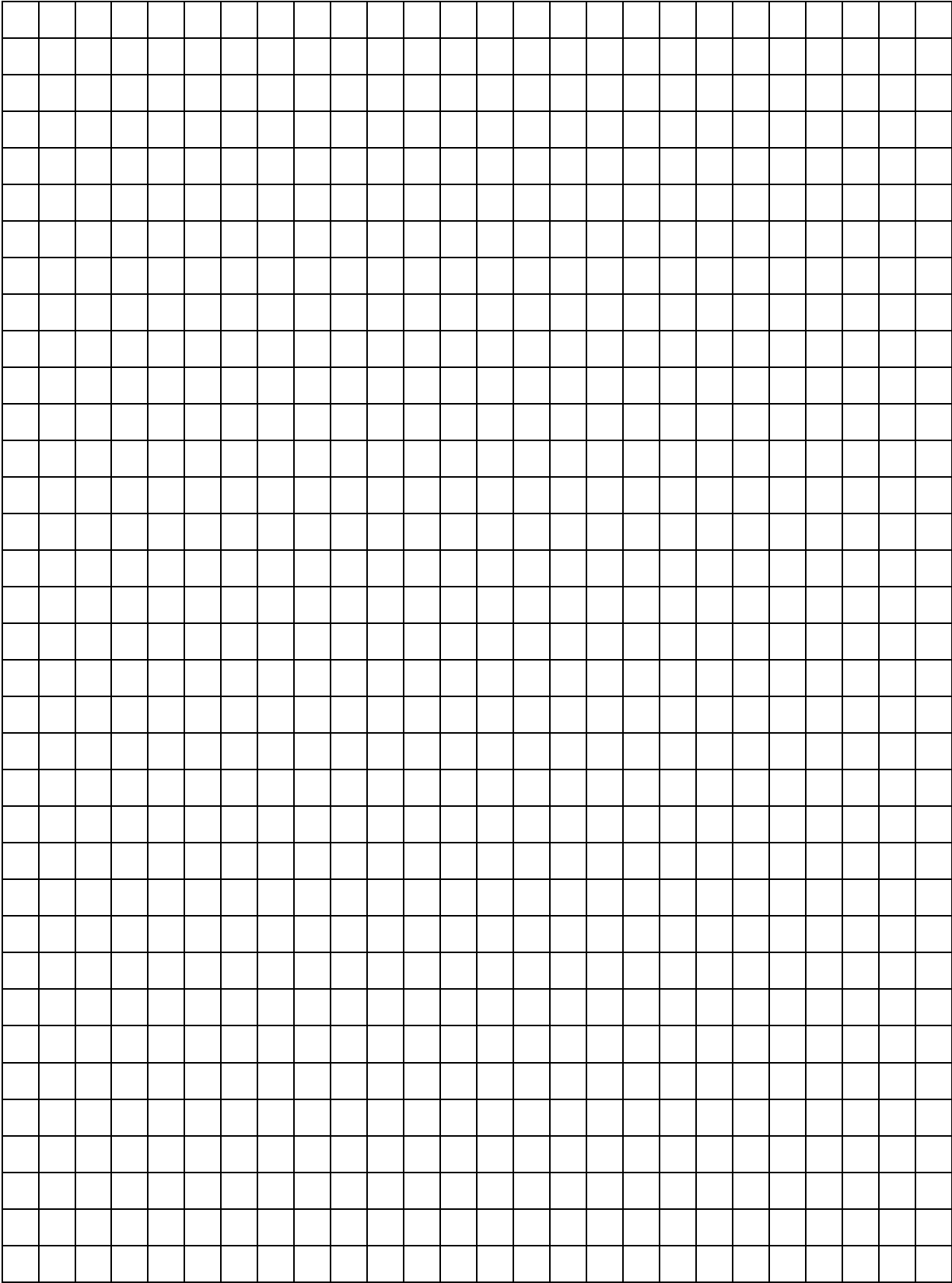

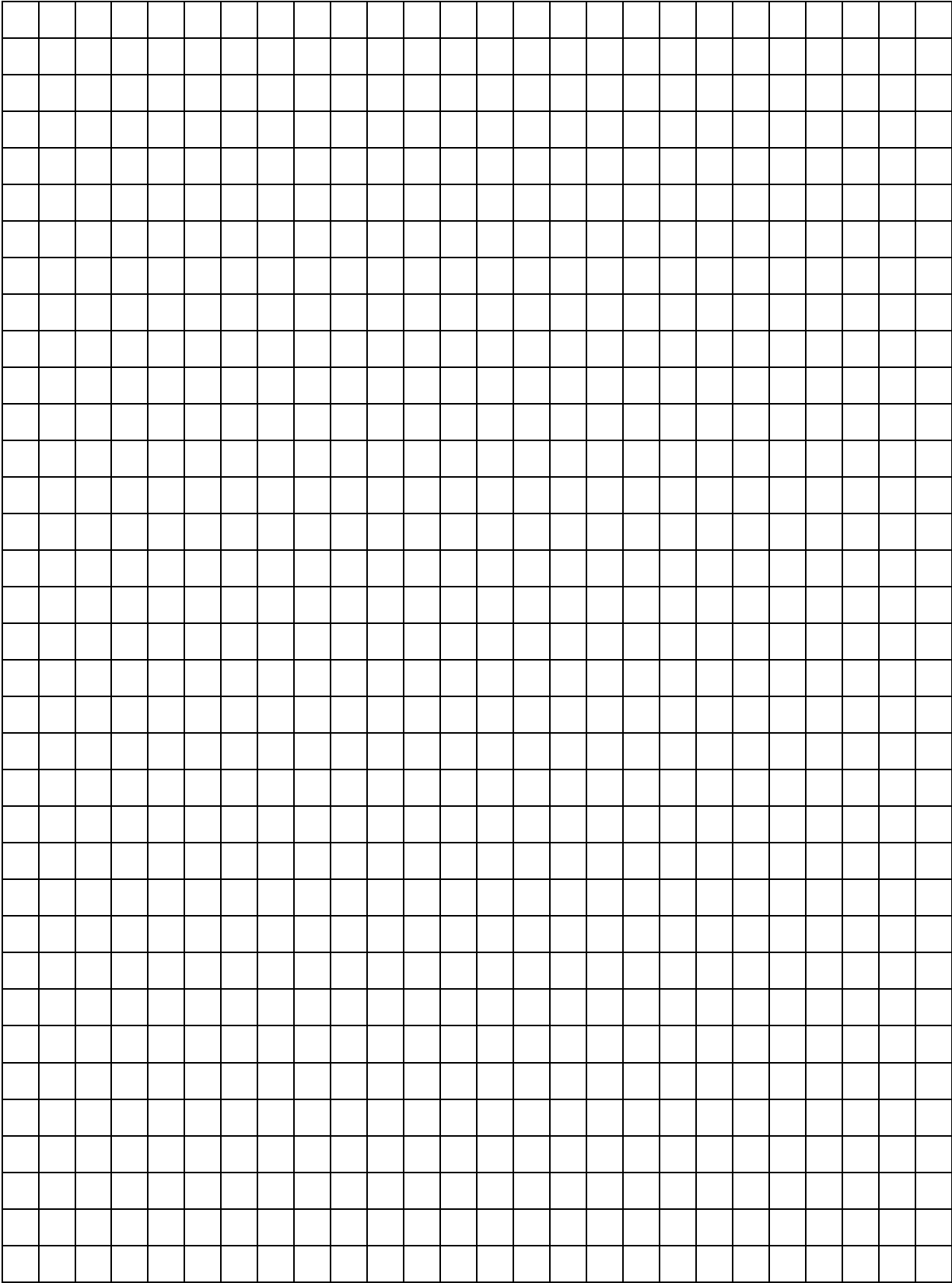

Multiplication Table (grid)

| | | | | | | | | | | |
|----|----|----|----|----|----|----|----|----|----|-----|
| x | 1 | 2 | 3 | 4 | 5 | 6 | 7 | 8 | 9 | 10 |
| 1 | 1 | 2 | 3 | 4 | 5 | 6 | 7 | 8 | 9 | 10 |
| 2 | 2 | 4 | 6 | 8 | 10 | 12 | 14 | 16 | 18 | 20 |
| 3 | 3 | 6 | 9 | 12 | 15 | 18 | 21 | 24 | 27 | 30 |
| 4 | 4 | 8 | 12 | 16 | 20 | 24 | 28 | 32 | 36 | 40 |
| 5 | 5 | 10 | 15 | 20 | 25 | 30 | 35 | 40 | 45 | 50 |
| 6 | 6 | 12 | 18 | 24 | 30 | 36 | 42 | 48 | 54 | 60 |
| 7 | 7 | 14 | 21 | 28 | 35 | 42 | 49 | 56 | 63 | 70 |
| 8 | 8 | 16 | 24 | 32 | 40 | 48 | 56 | 64 | 72 | 80 |
| 9 | 9 | 18 | 27 | 36 | 45 | 54 | 63 | 72 | 81 | 90 |
| 10 | 10 | 20 | 30 | 40 | 50 | 60 | 70 | 80 | 90 | 100 |

Multiplication Times Table Chart

| | | | | | |
|--------------------|--------------------|---------------------|----------------------|----------------------|----------------------|
| $1 \times 0 = 0$ | $2 \times 0 = 0$ | $3 \times 0 = 0$ | $4 \times 0 = 0$ | $5 \times 0 = 0$ | $6 \times 0 = 0$ |
| $1 \times 1 = 1$ | $2 \times 1 = 2$ | $3 \times 1 = 3$ | $4 \times 1 = 4$ | $5 \times 1 = 5$ | $6 \times 1 = 6$ |
| $1 \times 2 = 2$ | $2 \times 2 = 4$ | $3 \times 2 = 6$ | $4 \times 2 = 8$ | $5 \times 2 = 10$ | $6 \times 2 = 12$ |
| $1 \times 3 = 3$ | $2 \times 3 = 6$ | $3 \times 3 = 9$ | $4 \times 3 = 12$ | $5 \times 3 = 15$ | $6 \times 3 = 18$ |
| $1 \times 4 = 4$ | $2 \times 4 = 8$ | $3 \times 4 = 12$ | $4 \times 4 = 16$ | $5 \times 4 = 20$ | $6 \times 4 = 24$ |
| $1 \times 5 = 5$ | $2 \times 5 = 10$ | $3 \times 5 = 15$ | $4 \times 5 = 20$ | $5 \times 5 = 25$ | $6 \times 5 = 30$ |
| $1 \times 6 = 6$ | $2 \times 6 = 12$ | $3 \times 6 = 18$ | $4 \times 6 = 24$ | $5 \times 6 = 30$ | $6 \times 6 = 36$ |
| $1 \times 7 = 7$ | $2 \times 7 = 14$ | $3 \times 7 = 21$ | $4 \times 7 = 28$ | $5 \times 7 = 35$ | $6 \times 7 = 42$ |
| $1 \times 8 = 8$ | $2 \times 8 = 16$ | $3 \times 8 = 24$ | $4 \times 8 = 32$ | $5 \times 8 = 40$ | $6 \times 8 = 48$ |
| $1 \times 9 = 9$ | $2 \times 9 = 18$ | $3 \times 9 = 27$ | $4 \times 9 = 36$ | $5 \times 9 = 45$ | $6 \times 9 = 54$ |
| $1 \times 10 = 10$ | $2 \times 10 = 20$ | $3 \times 10 = 30$ | $4 \times 10 = 40$ | $5 \times 10 = 50$ | $6 \times 10 = 60$ |
| $1 \times 11 = 11$ | $2 \times 11 = 22$ | $3 \times 11 = 33$ | $4 \times 11 = 44$ | $5 \times 11 = 55$ | $6 \times 11 = 66$ |
| $1 \times 12 = 12$ | $2 \times 12 = 24$ | $3 \times 12 = 36$ | $4 \times 12 = 48$ | $5 \times 12 = 60$ | $6 \times 12 = 72$ |
| $7 \times 0 = 0$ | $8 \times 0 = 0$ | $9 \times 0 = 0$ | $10 \times 0 = 0$ | $11 \times 0 = 0$ | $12 \times 0 = 0$ |
| $7 \times 1 = 7$ | $8 \times 1 = 8$ | $9 \times 1 = 9$ | $10 \times 1 = 10$ | $11 \times 1 = 11$ | $12 \times 1 = 12$ |
| $7 \times 2 = 14$ | $8 \times 2 = 16$ | $9 \times 2 = 18$ | $10 \times 2 = 20$ | $11 \times 2 = 22$ | $12 \times 2 = 24$ |
| $7 \times 3 = 21$ | $8 \times 3 = 24$ | $9 \times 3 = 27$ | $10 \times 3 = 30$ | $11 \times 3 = 33$ | $12 \times 3 = 36$ |
| $7 \times 4 = 28$ | $8 \times 4 = 32$ | $9 \times 4 = 36$ | $10 \times 4 = 40$ | $11 \times 4 = 44$ | $12 \times 4 = 48$ |
| $7 \times 5 = 35$ | $8 \times 5 = 40$ | $9 \times 5 = 45$ | $10 \times 5 = 50$ | $11 \times 5 = 55$ | $12 \times 5 = 60$ |
| $7 \times 6 = 42$ | $8 \times 6 = 48$ | $9 \times 6 = 54$ | $10 \times 6 = 60$ | $11 \times 6 = 66$ | $12 \times 6 = 72$ |
| $7 \times 7 = 49$ | $8 \times 7 = 56$ | $9 \times 7 = 63$ | $10 \times 7 = 70$ | $11 \times 7 = 77$ | $12 \times 7 = 84$ |
| $7 \times 8 = 56$ | $8 \times 8 = 64$ | $9 \times 8 = 72$ | $10 \times 8 = 80$ | $11 \times 8 = 88$ | $12 \times 8 = 96$ |
| $7 \times 9 = 63$ | $8 \times 9 = 72$ | $9 \times 9 = 81$ | $10 \times 9 = 90$ | $11 \times 9 = 99$ | $12 \times 9 = 108$ |
| $7 \times 10 = 70$ | $8 \times 10 = 80$ | $9 \times 10 = 90$ | $10 \times 10 = 100$ | $11 \times 10 = 110$ | $12 \times 10 = 120$ |
| $7 \times 11 = 77$ | $8 \times 11 = 88$ | $9 \times 11 = 99$ | $10 \times 11 = 110$ | $11 \times 11 = 121$ | $12 \times 11 = 132$ |
| $7 \times 12 = 84$ | $8 \times 12 = 96$ | $9 \times 12 = 108$ | $10 \times 12 = 120$ | $11 \times 12 = 132$ | $12 \times 12 = 144$ |